

INSTRUCTION MANUAL

1/8TH SCALE 4WD NITRO POWERED RACE CAR



SICUREZZA:

Questo automodello in funzionamento ha parti in movimento: prestare attenzione.

Questo automodello in funzionamento ha parti che raggiungono temperature elevate: attenzione a non scottarsi.

Questo automodello non è un giocattolo. In caso di utilizzo da parte di un minore, è necessaria la supervisione di un adulto.

This model car in operation has moving parts: pay attention.

This model car in operation has parts that reach high temperatures: be careful not to burn yourself.

This model car is not a toy. If used by a minor, adult supervision is required.

AVVERTENZE:

Non utilizzare l'automodello al di fuori di percorsi sicuri oppure in aree aperte al traffico.

Non utilizzare in situazioni ove sono presenti persone od animali. Pericolo di danni fisici a se stessi ed ad altri.

Non utilizzare l'automodello in presenza di incendi, fuochi, fiamme libere o laghi, fiumi, specchi d'acqua.

Non utilizzare l'automodello in caso di batterie scariche o comportamenti anomali.

Do not use the model car outside of safe routes or in areas open to traffic.

Do not use in situations where people or animals are present. Danger of physical harm to oneself and to others.

Do not use the model car in the presence of fires, fires, open flames or lakes, rivers, ponds.

Do not use the car in the event of flat batteries or abnormal behavior.

ACCESSORI:

Per completare l'automodello è necessario acquistare a parte:

Il motore con la marmitta. Il radiocomando con i servi e le batterie.

La miscela con il riempitore e la cassetta di avviamento. Inoltre carrozzeria, vernici ed accessori relativi.

To complete the model car it is necessary to purchase separately:

The engine with the muffler. The remote control with servos and batteries.

The mixture with the filler and the starter box. Also bodywork, paints and related accessories.

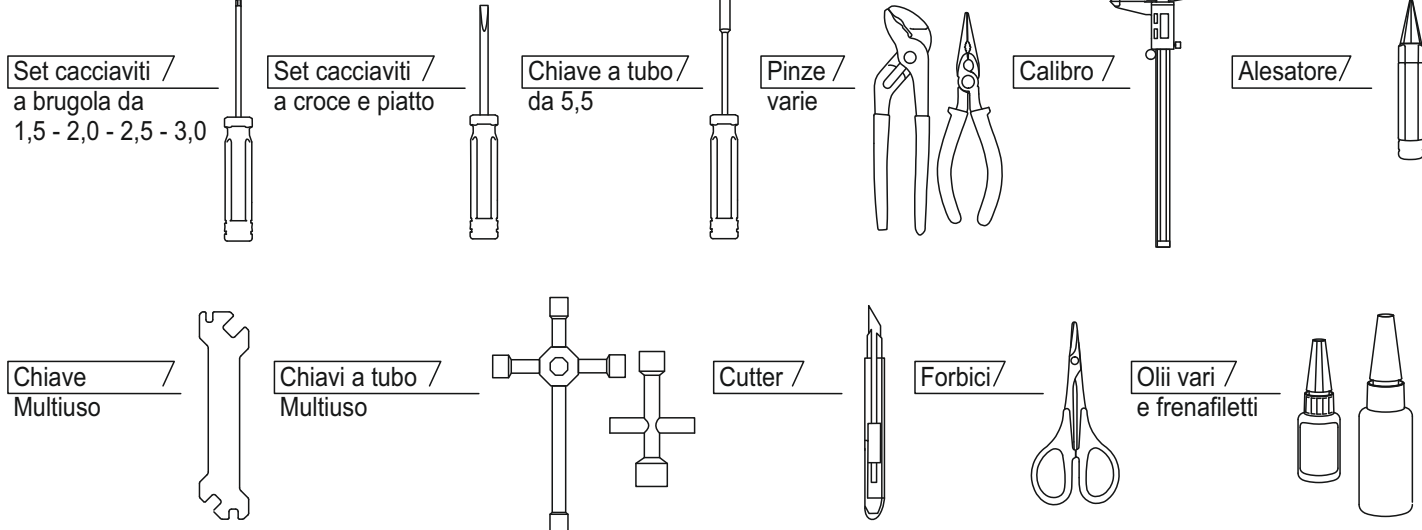
ATTREZZI:**CONCLUSIONI:**

Grazie per aver preferito un prodotto BMT.

Leggere attentamente le istruzioni. Per ogni fase le parti necessarie sono sia nelle buste che nei blister. Prestare attenzione.

Siamo a disposizione per risolvere ogni eventuale problema, sia di montaggio che di settaggio.

Buon divertimento dal TEAM BMT.

Thank you for choosing a BMT product.

Read the instructions carefully. For each phase the necessary parts are both in the bags and in the blister packs. Pay attention.

We are available to solve any problem, both in terms of assembly and setting.

Have fun from the BMT TEAM.

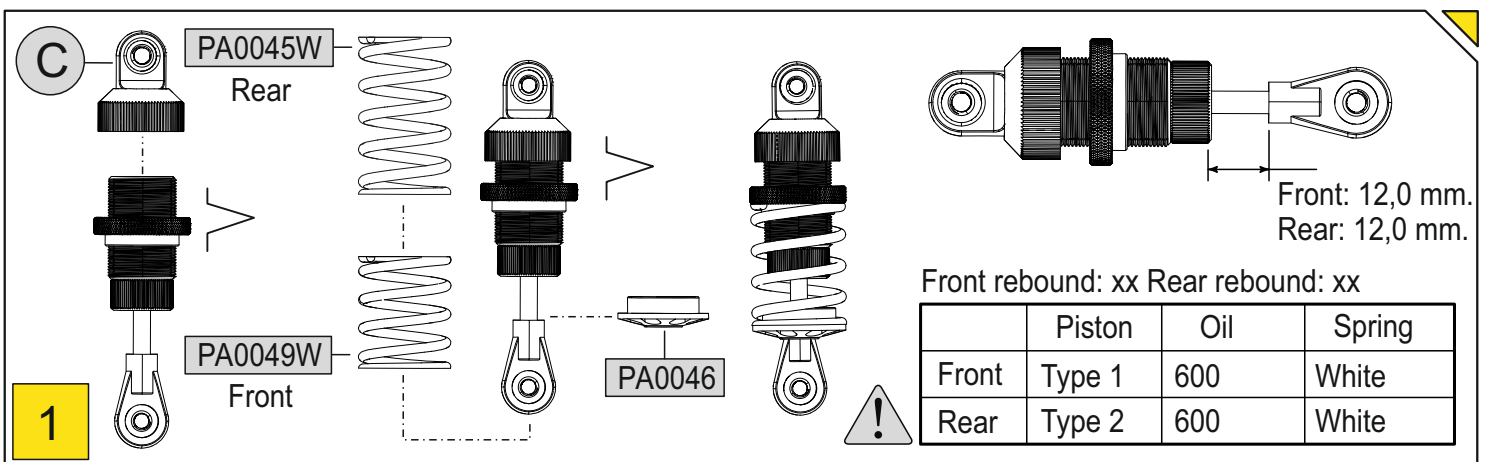
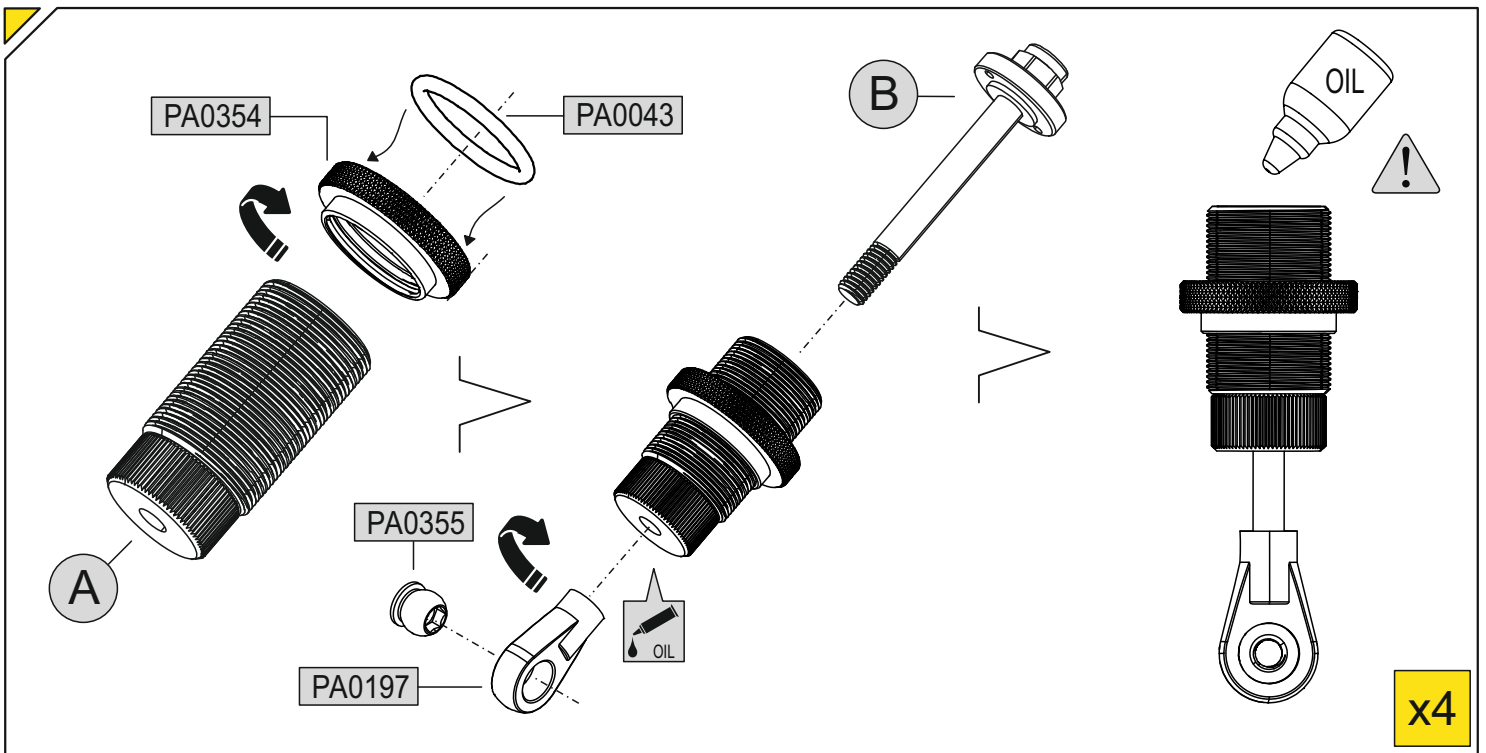
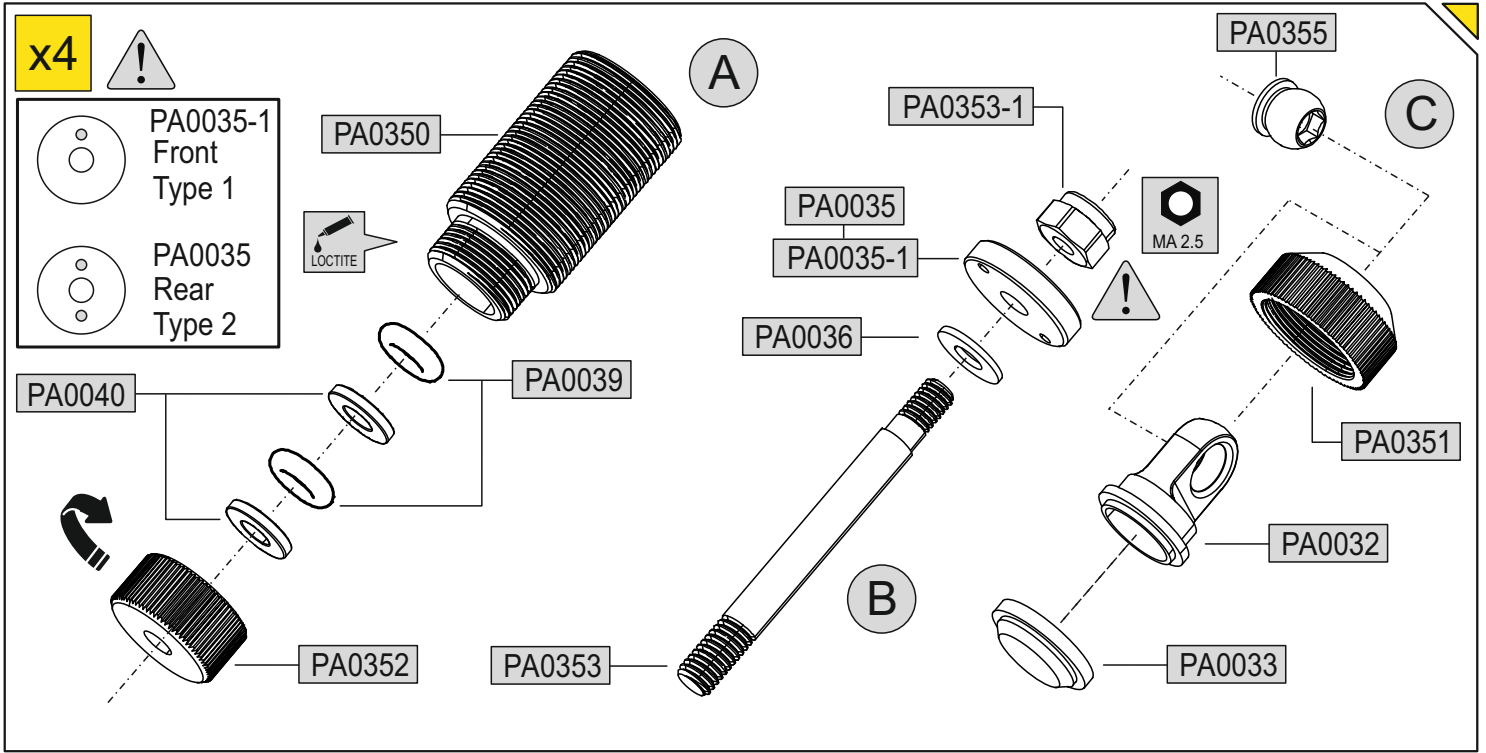

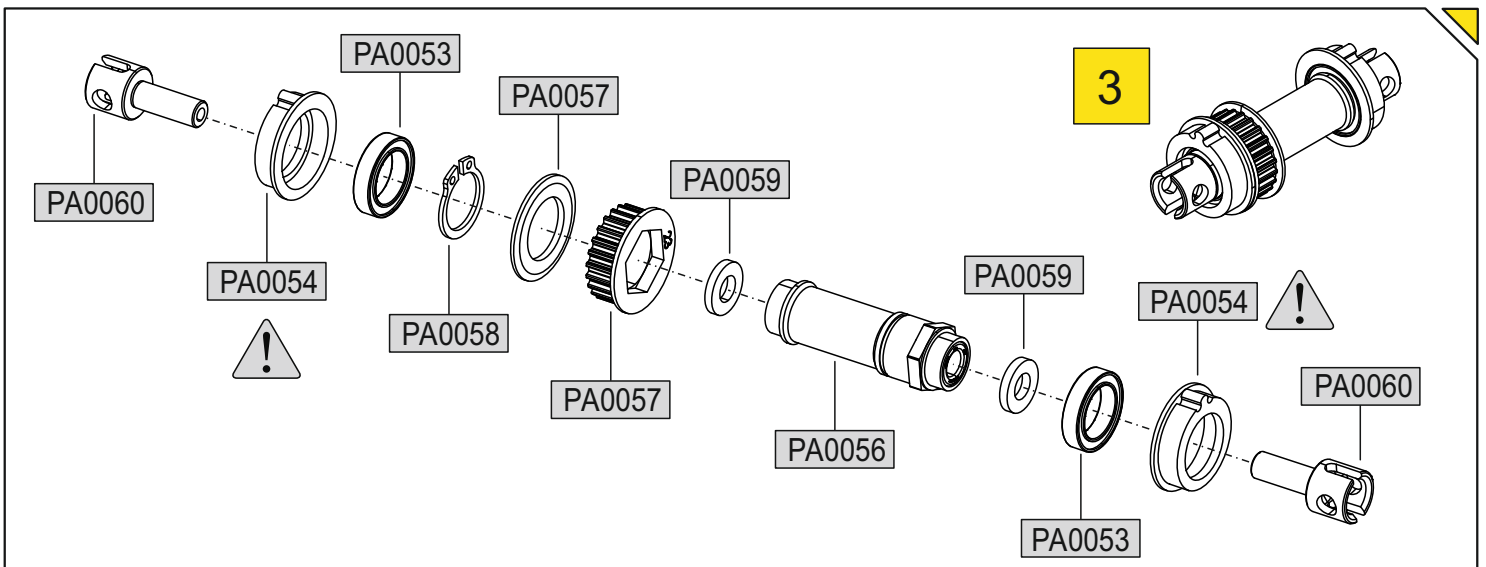
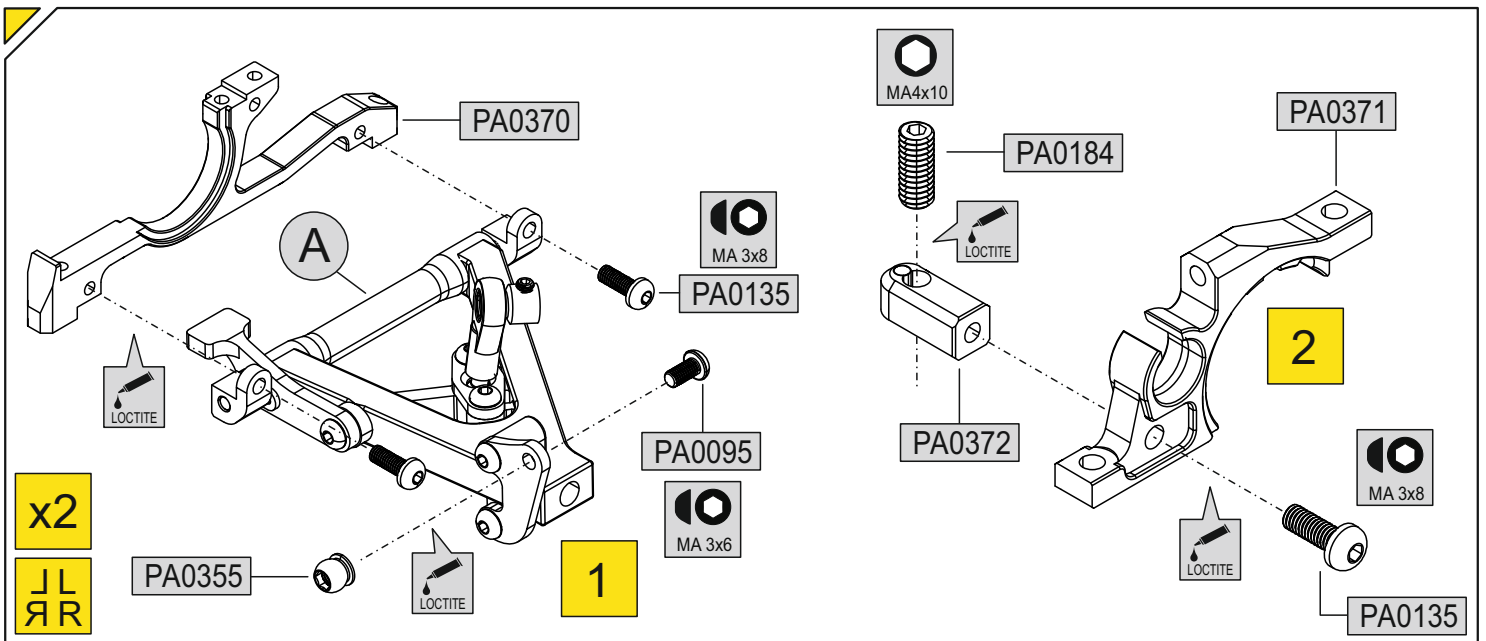
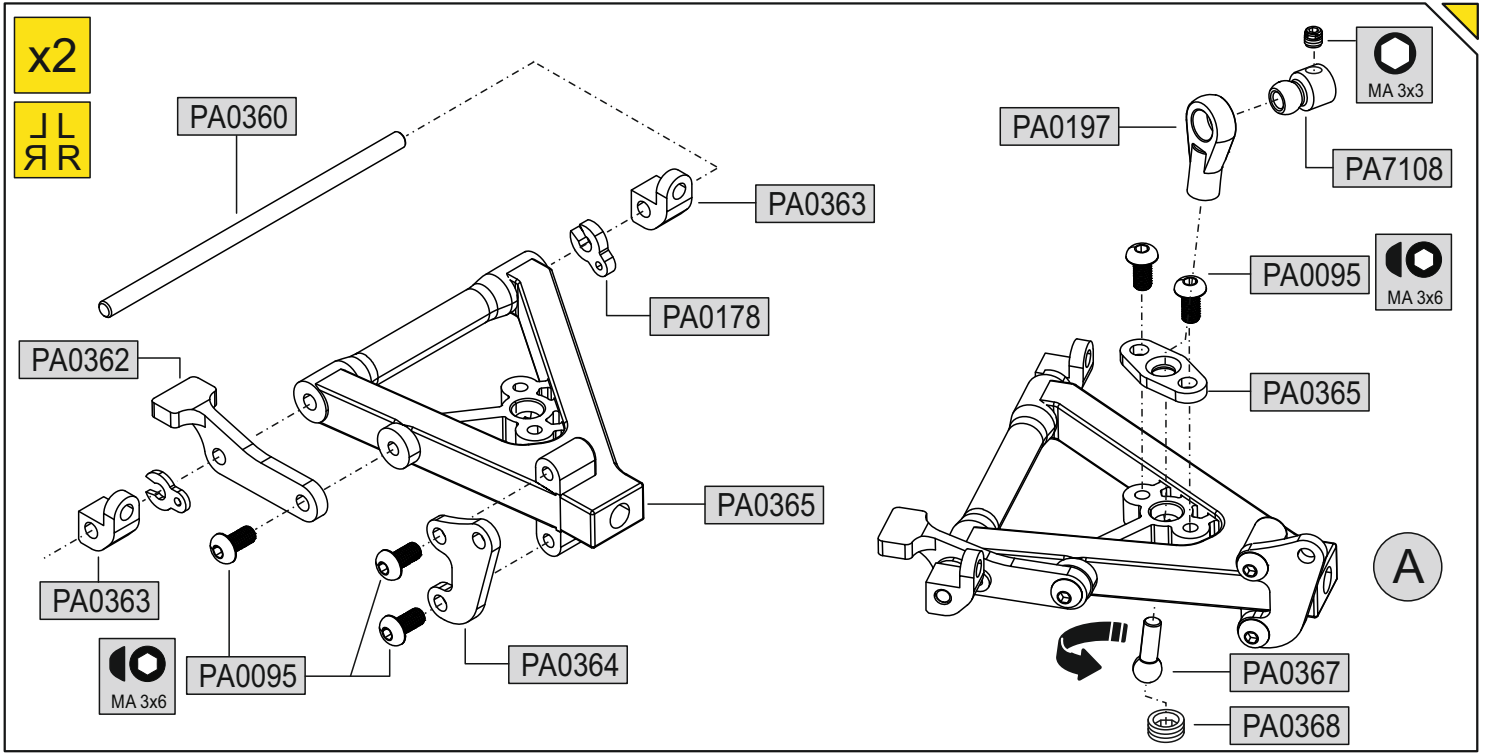

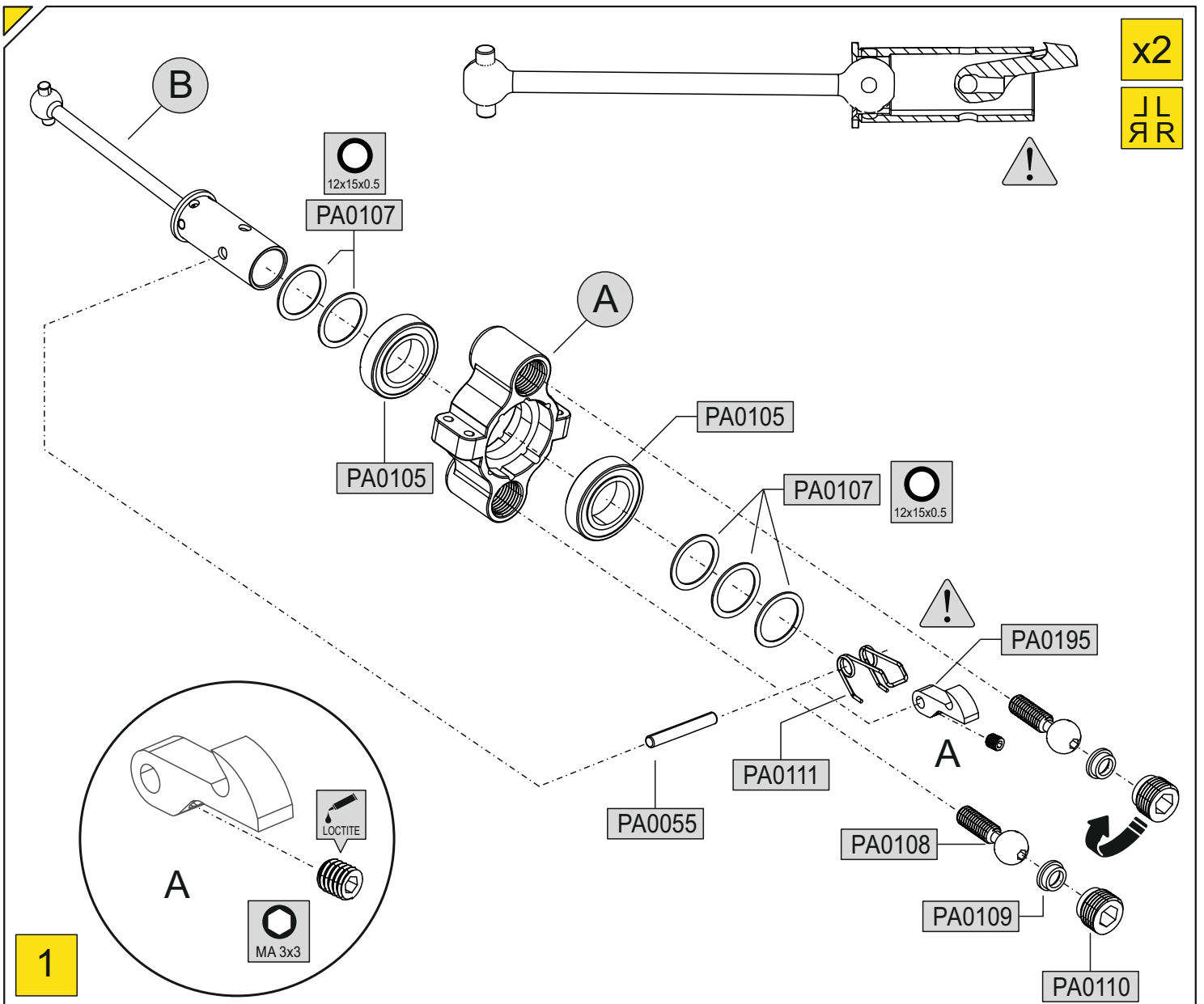
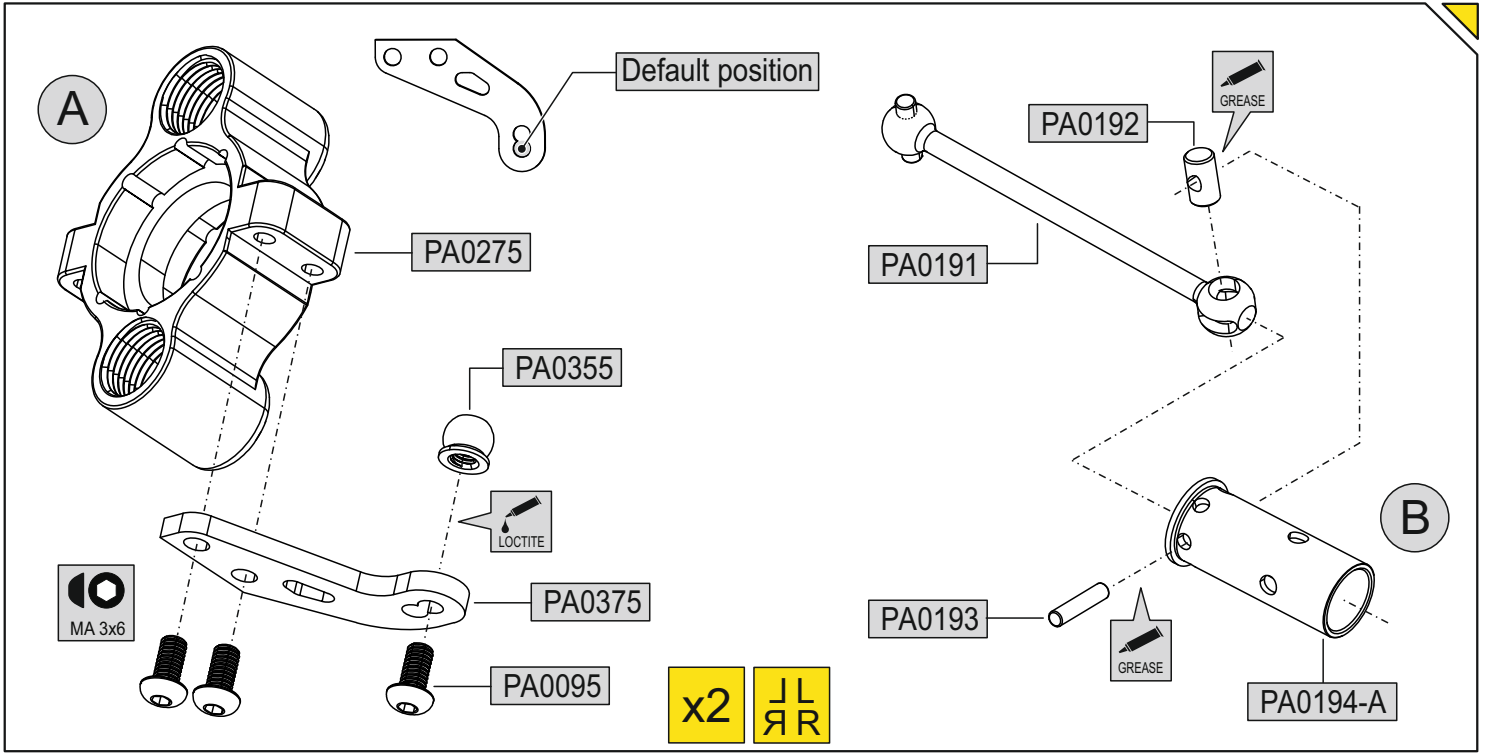

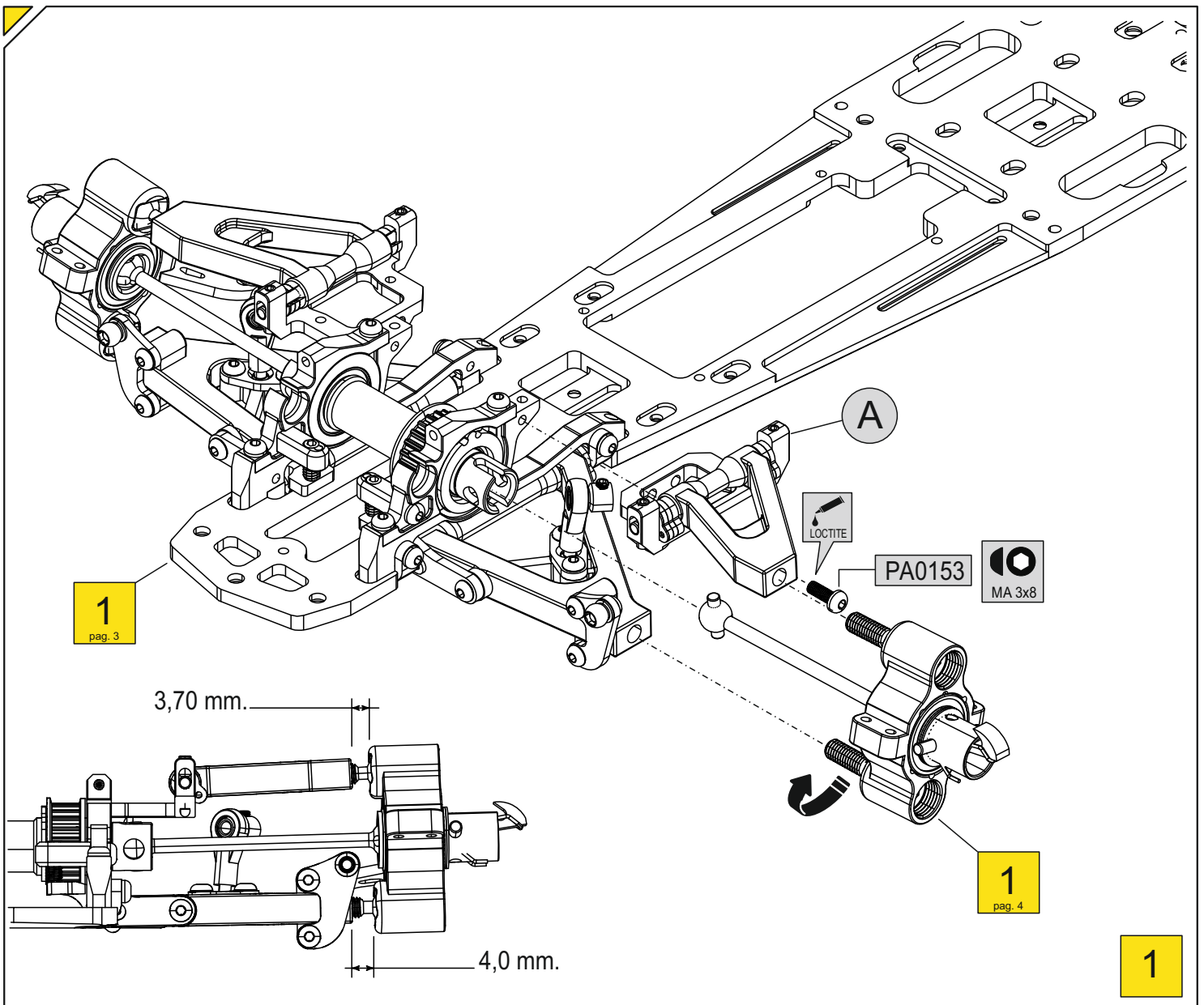
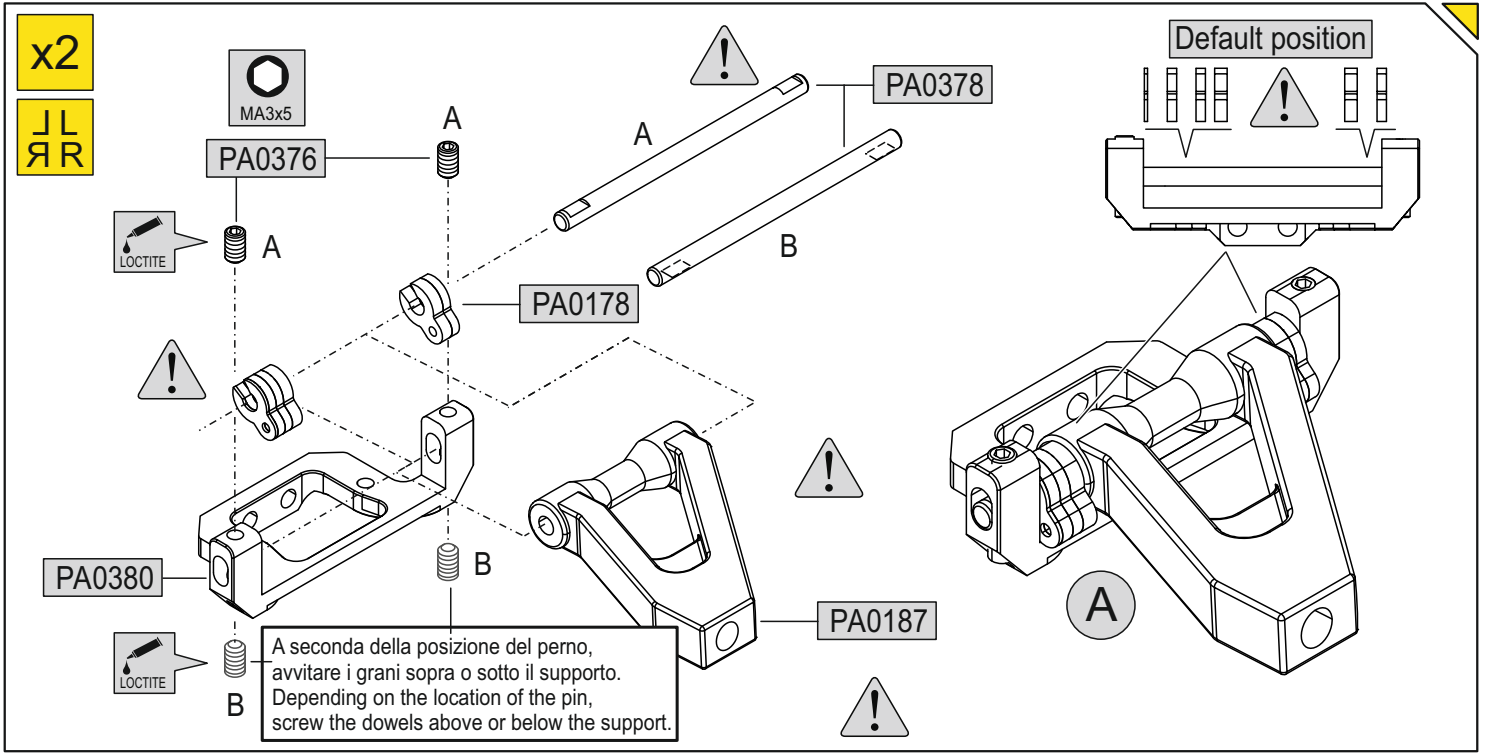

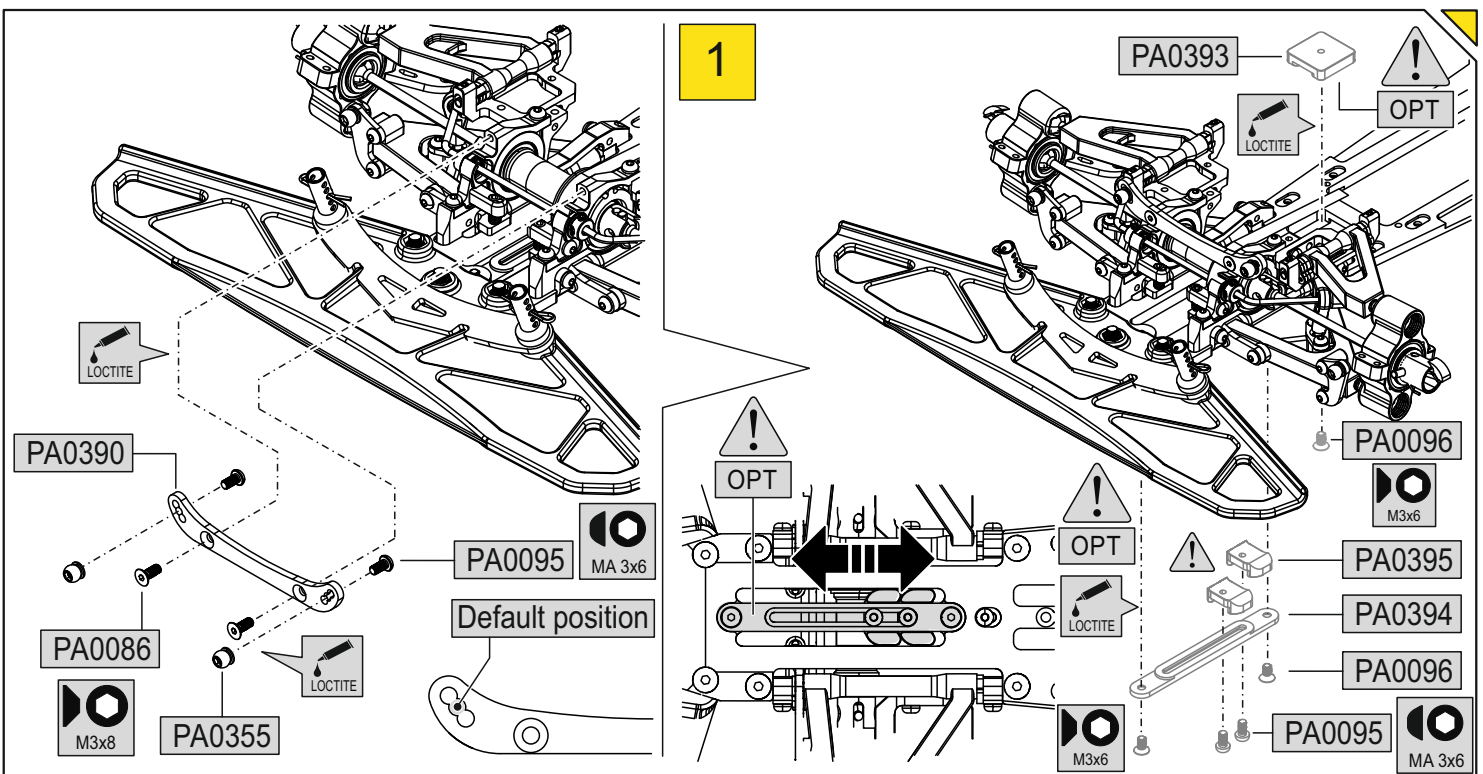
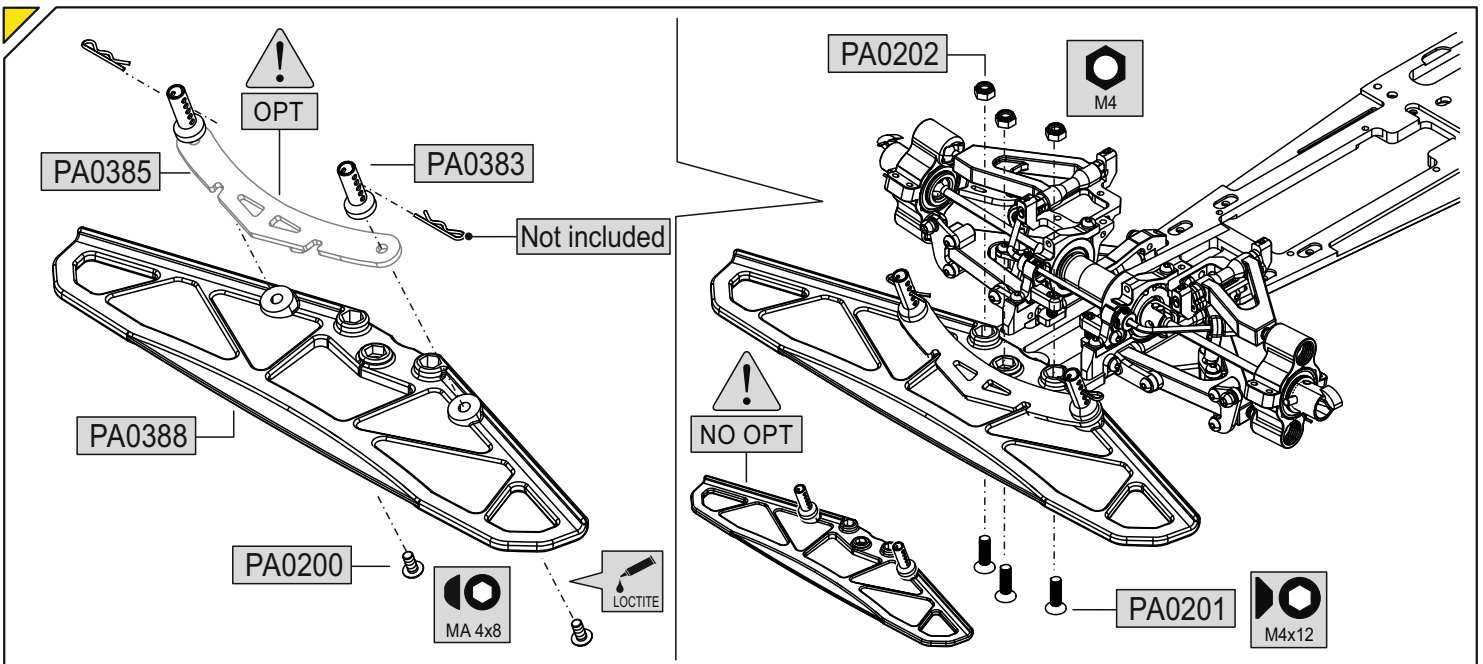
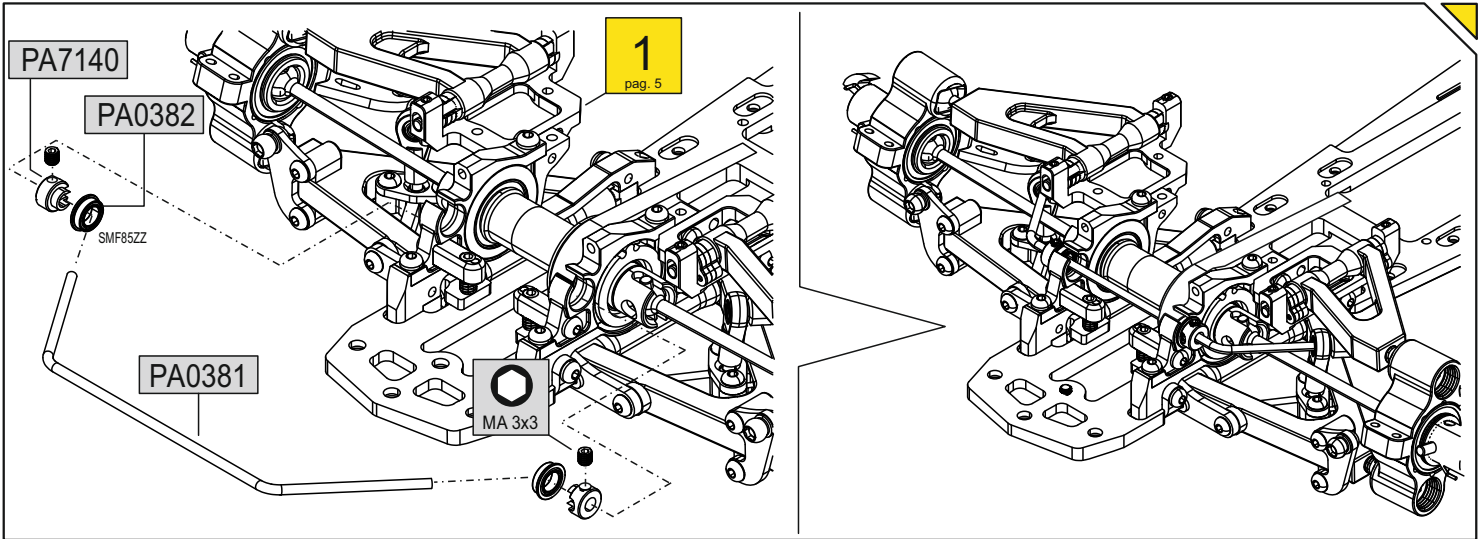

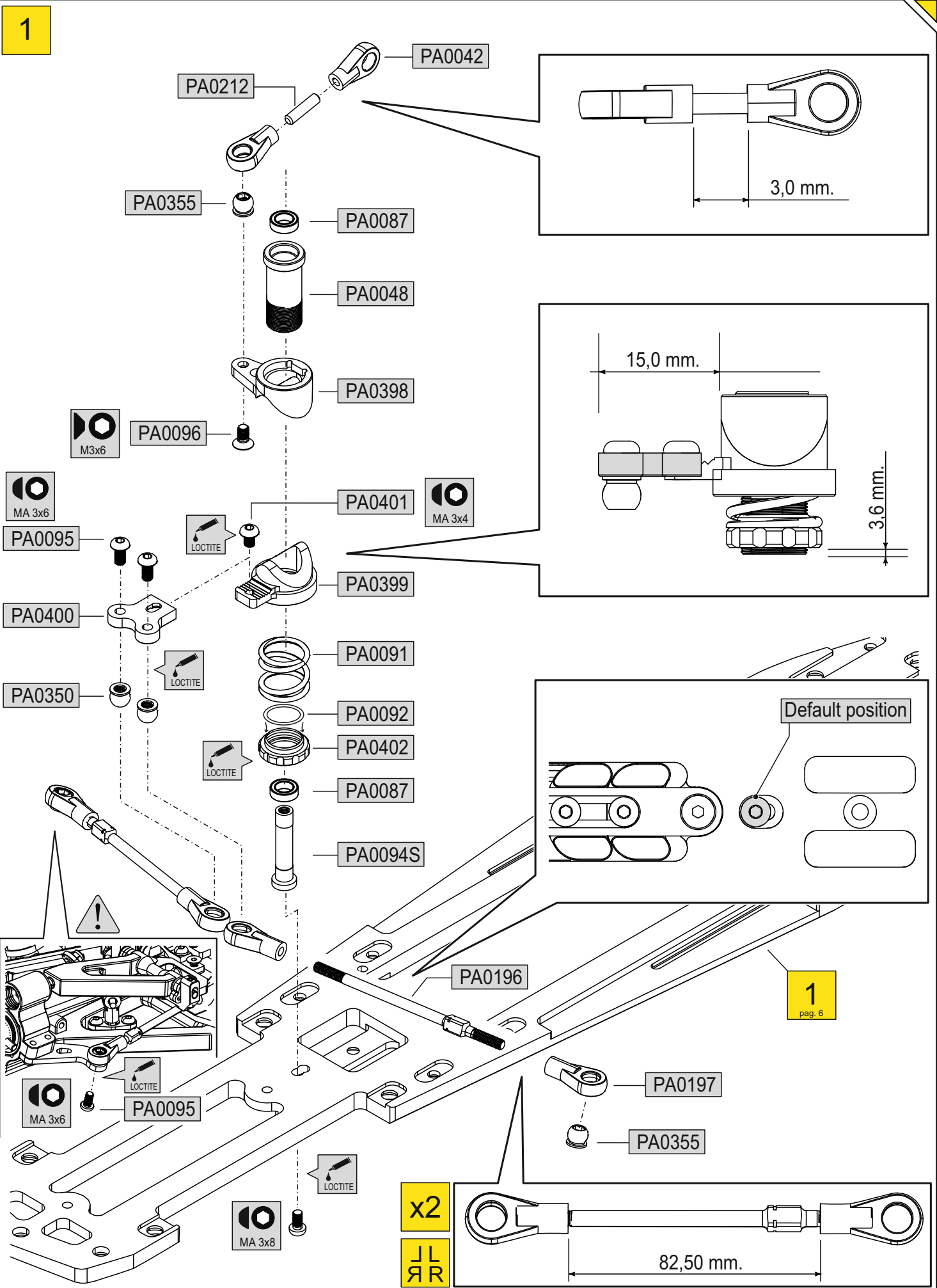

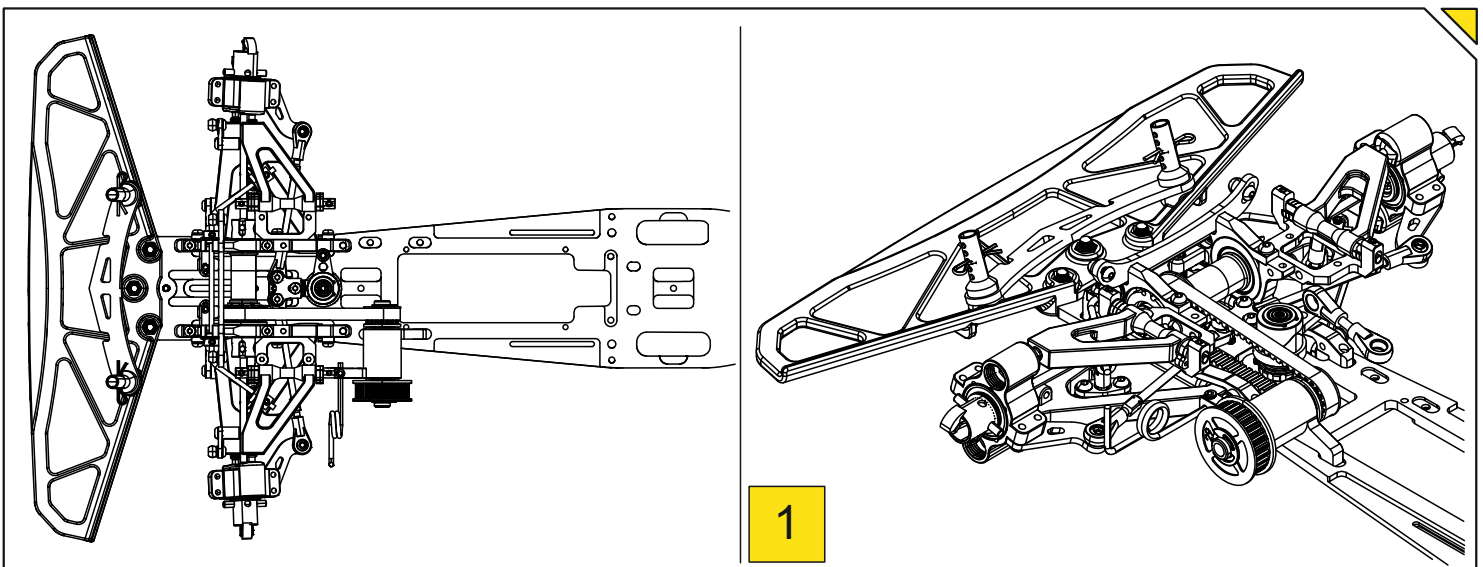
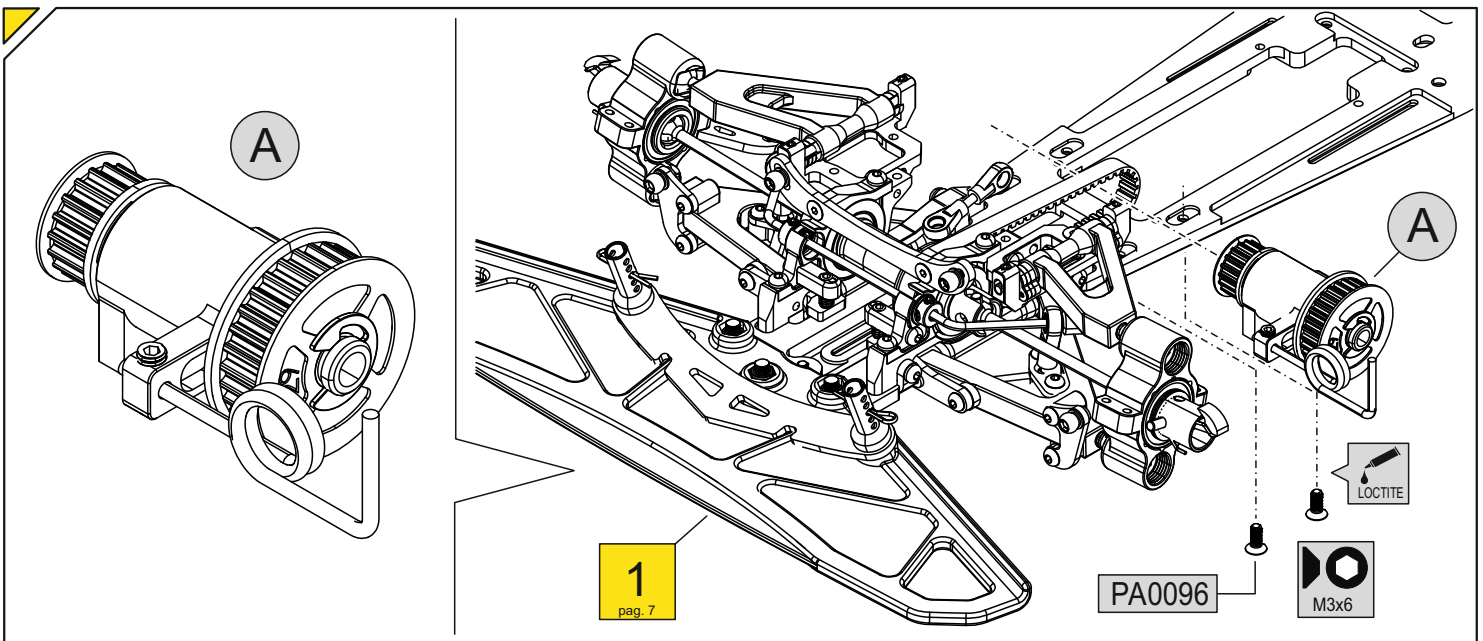
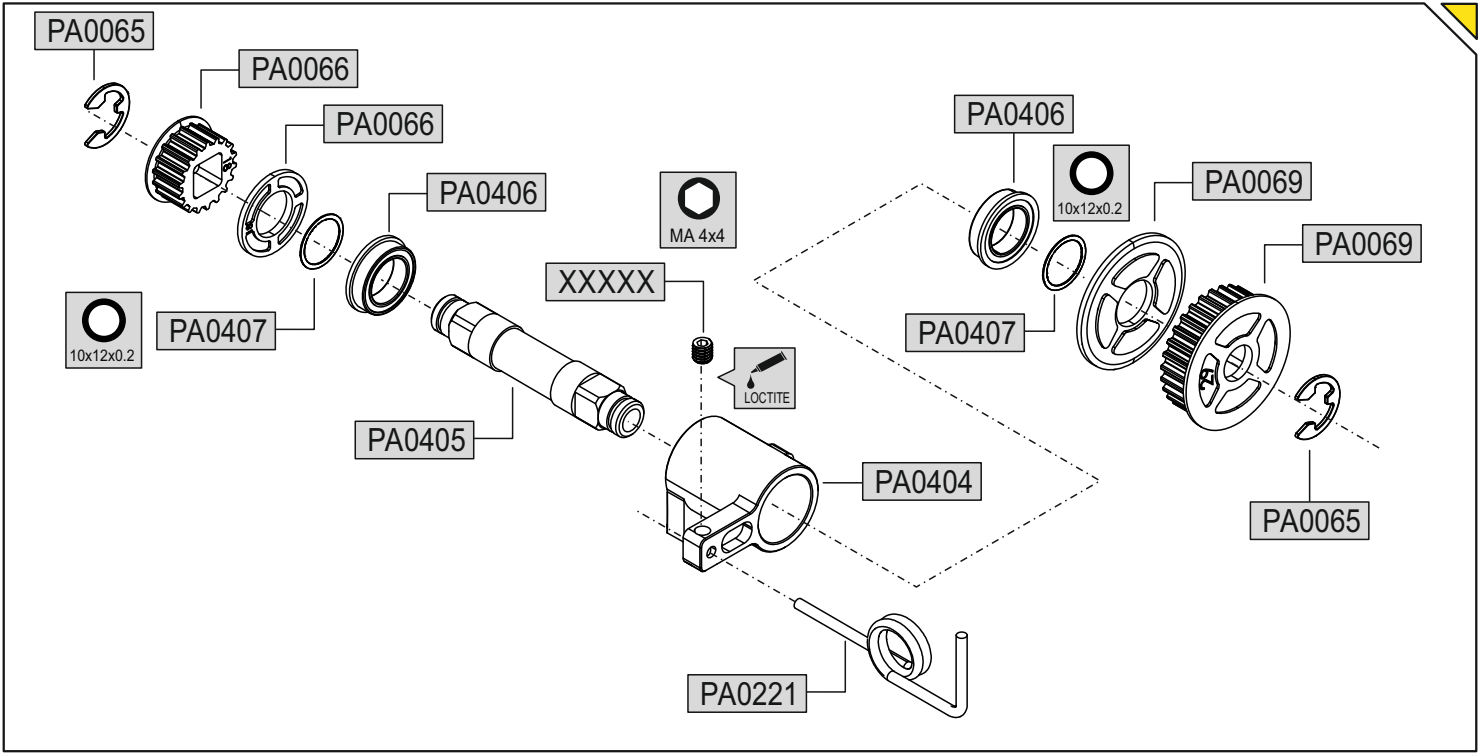

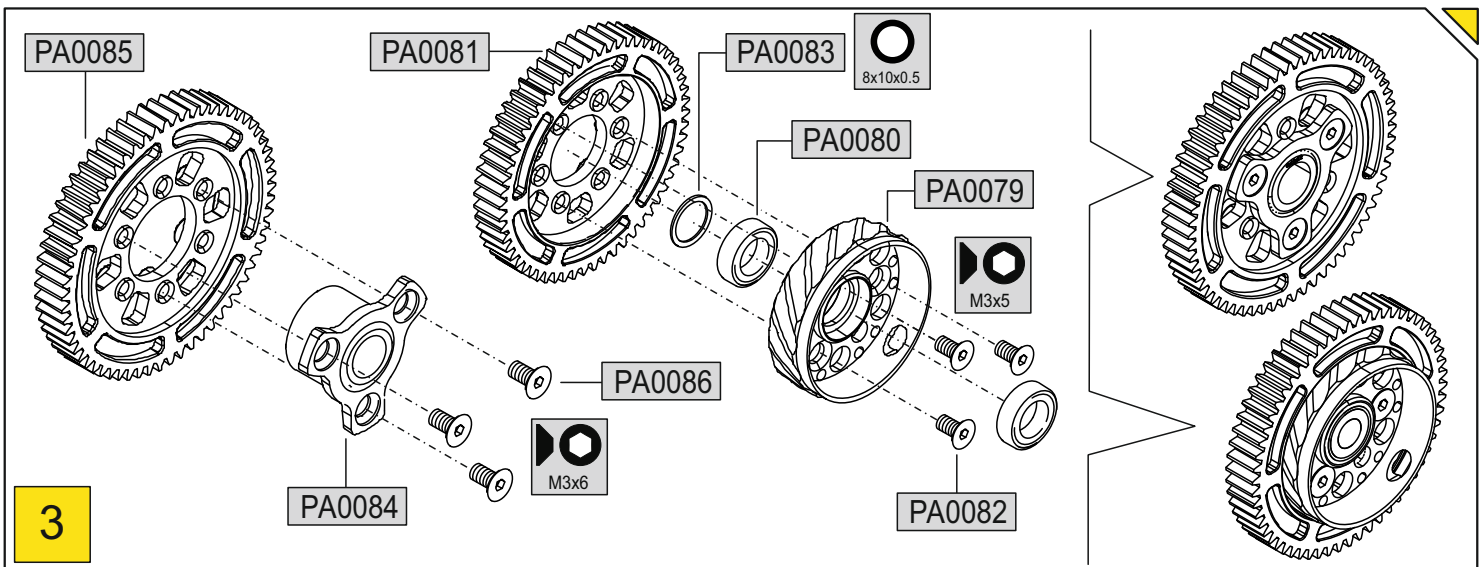
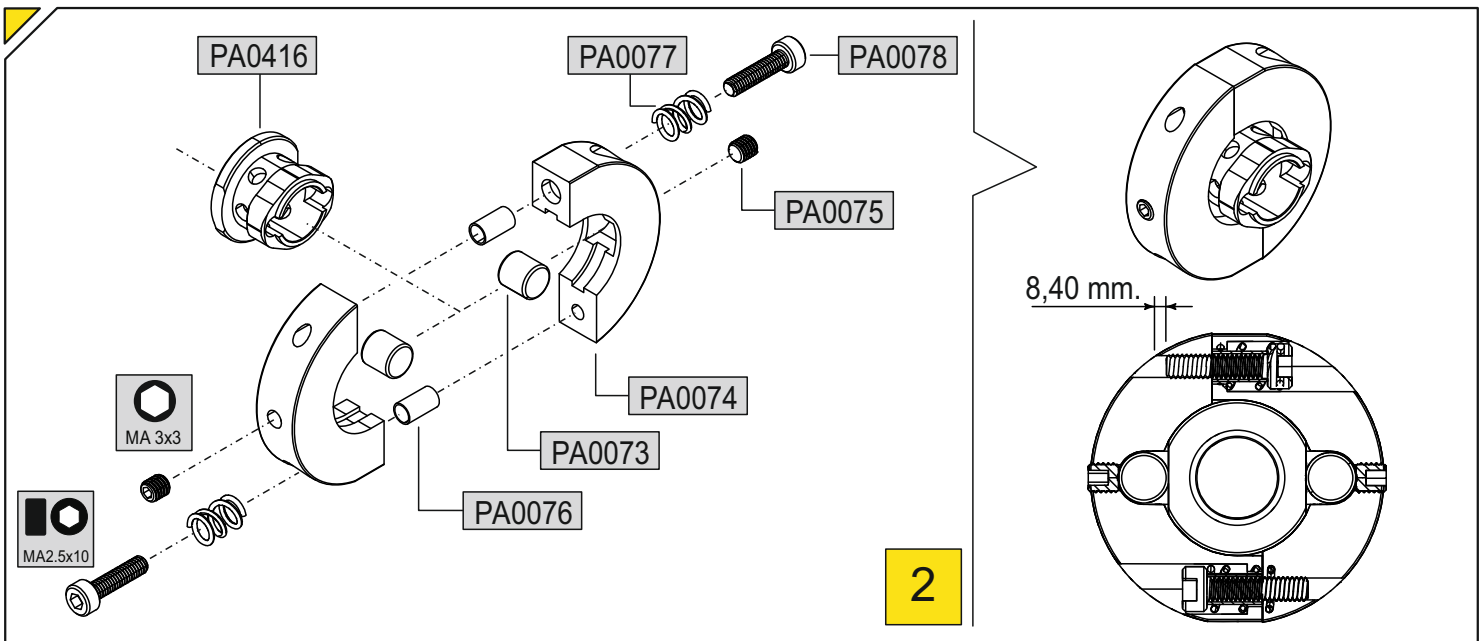
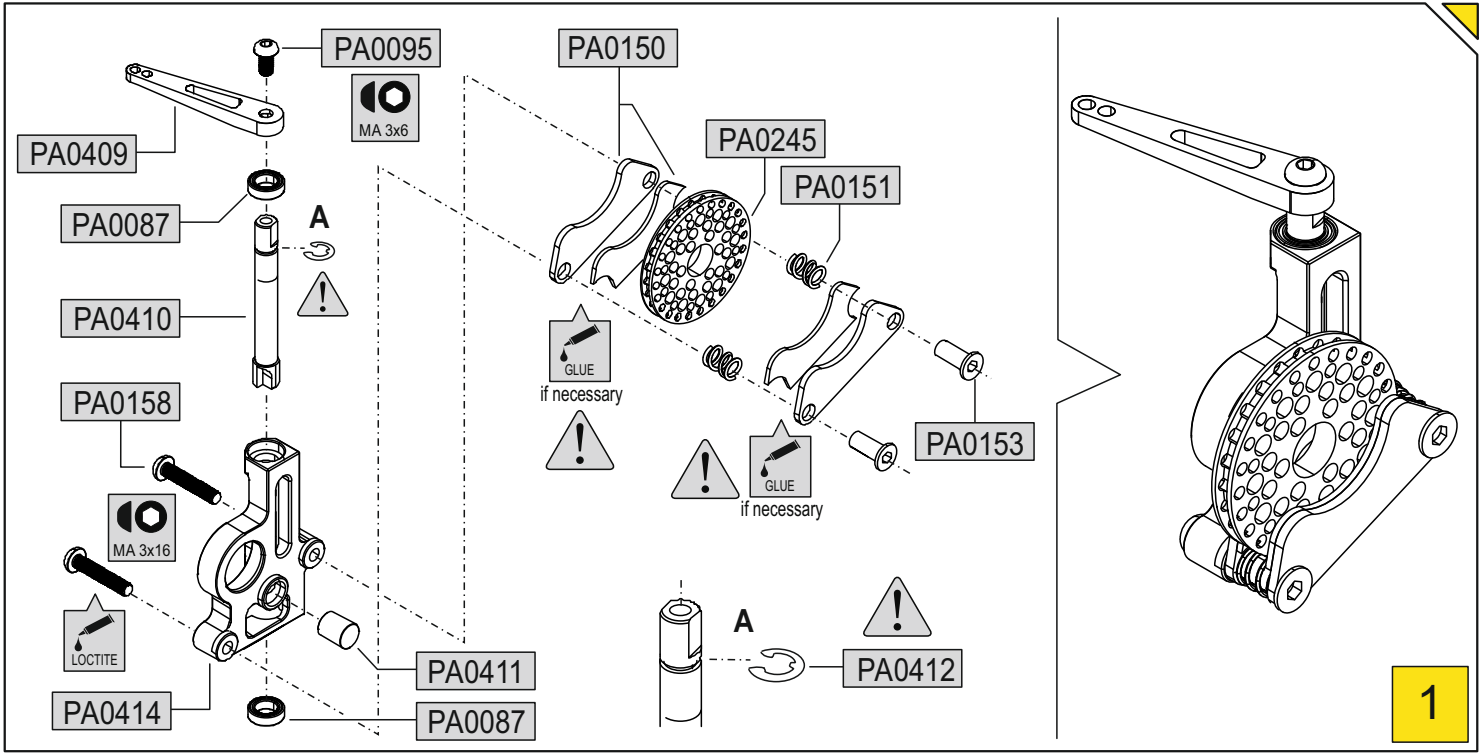

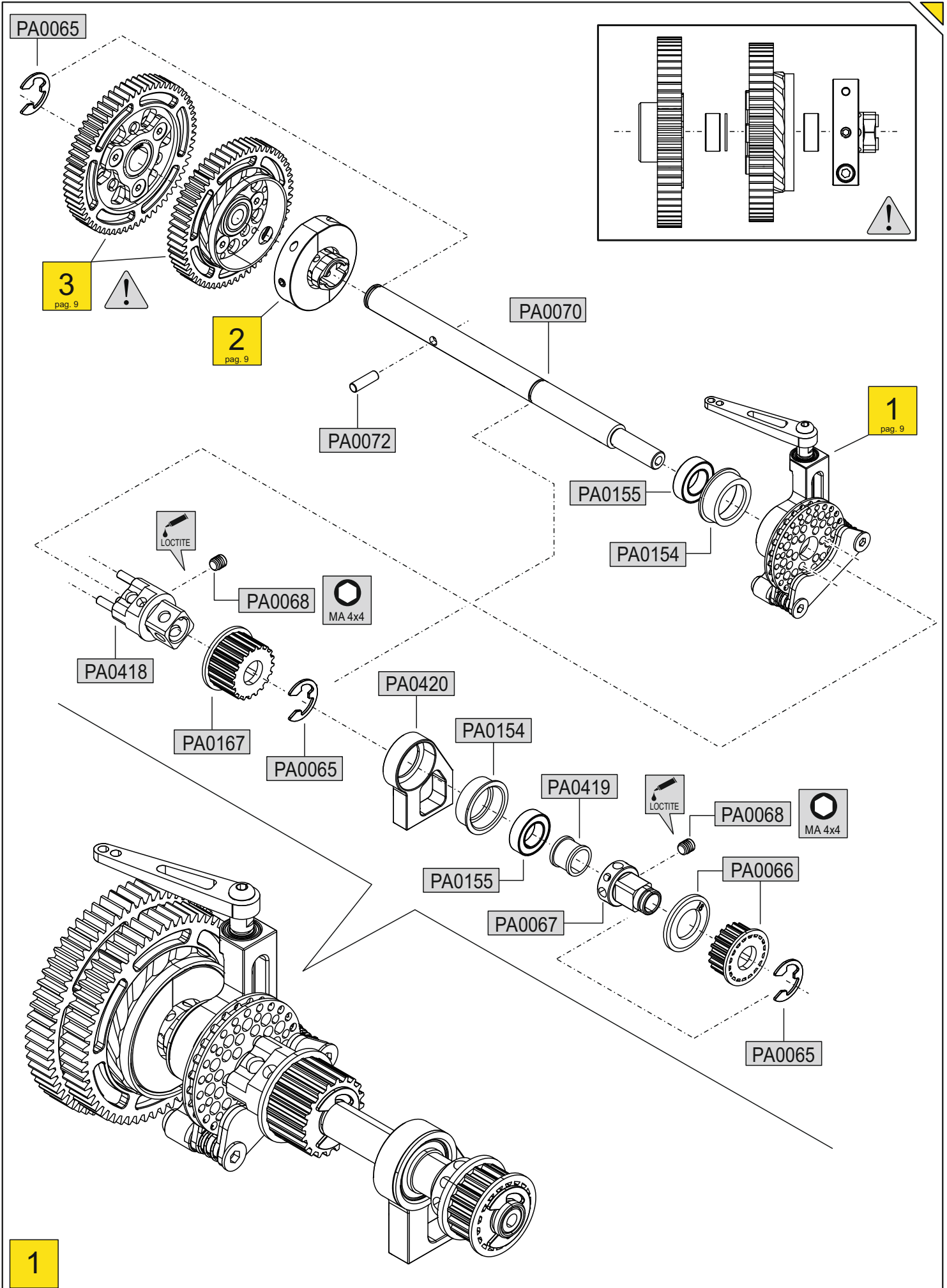

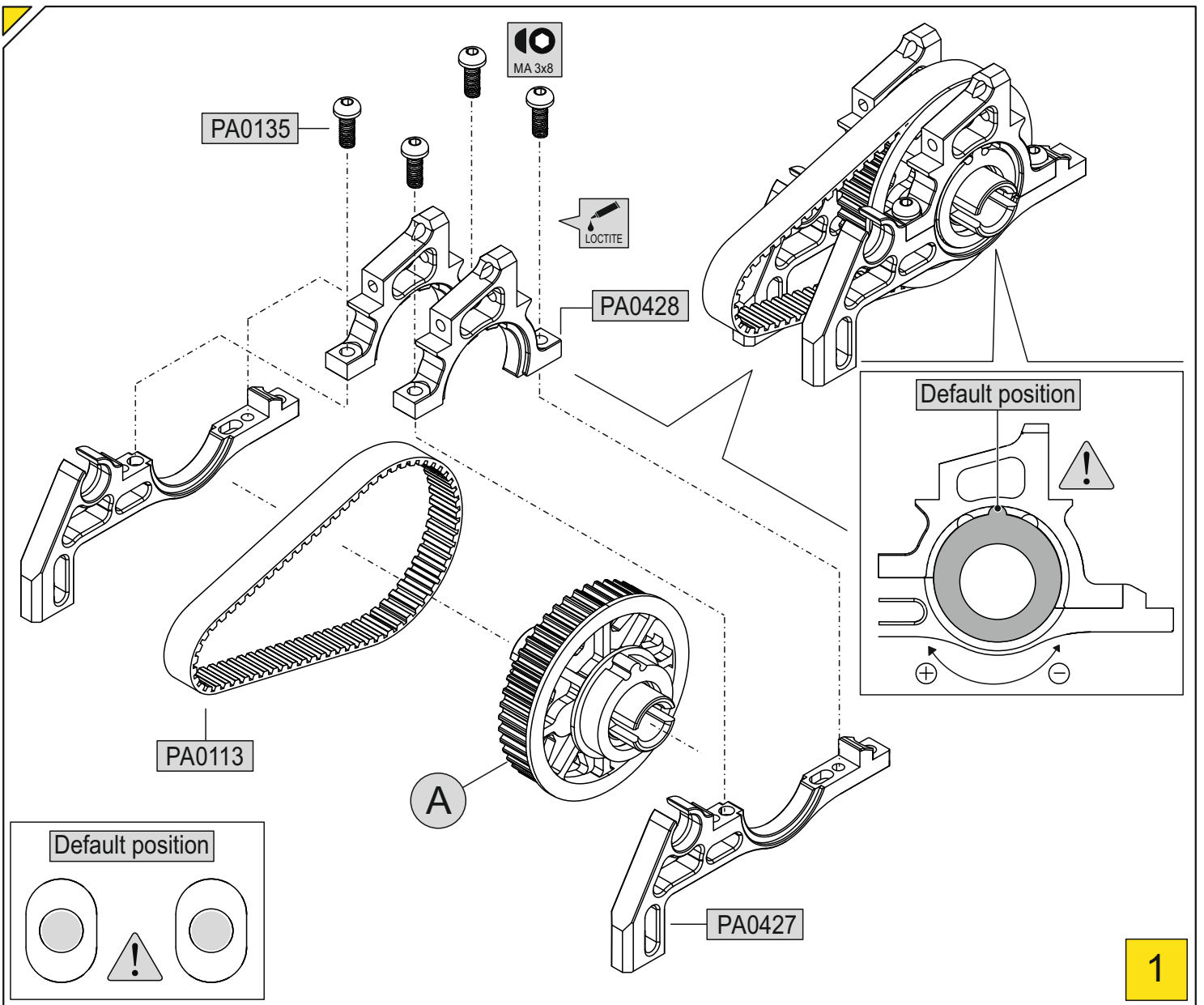
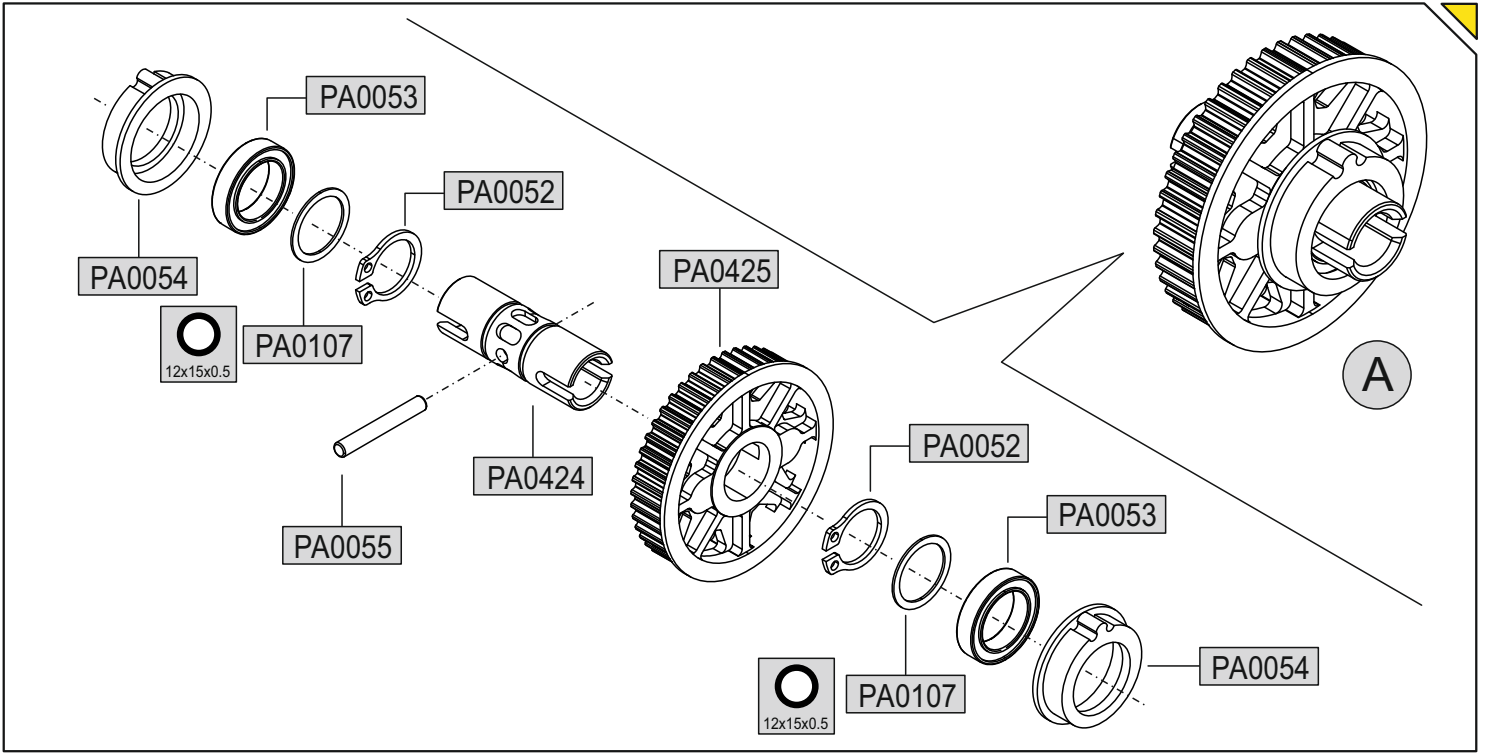

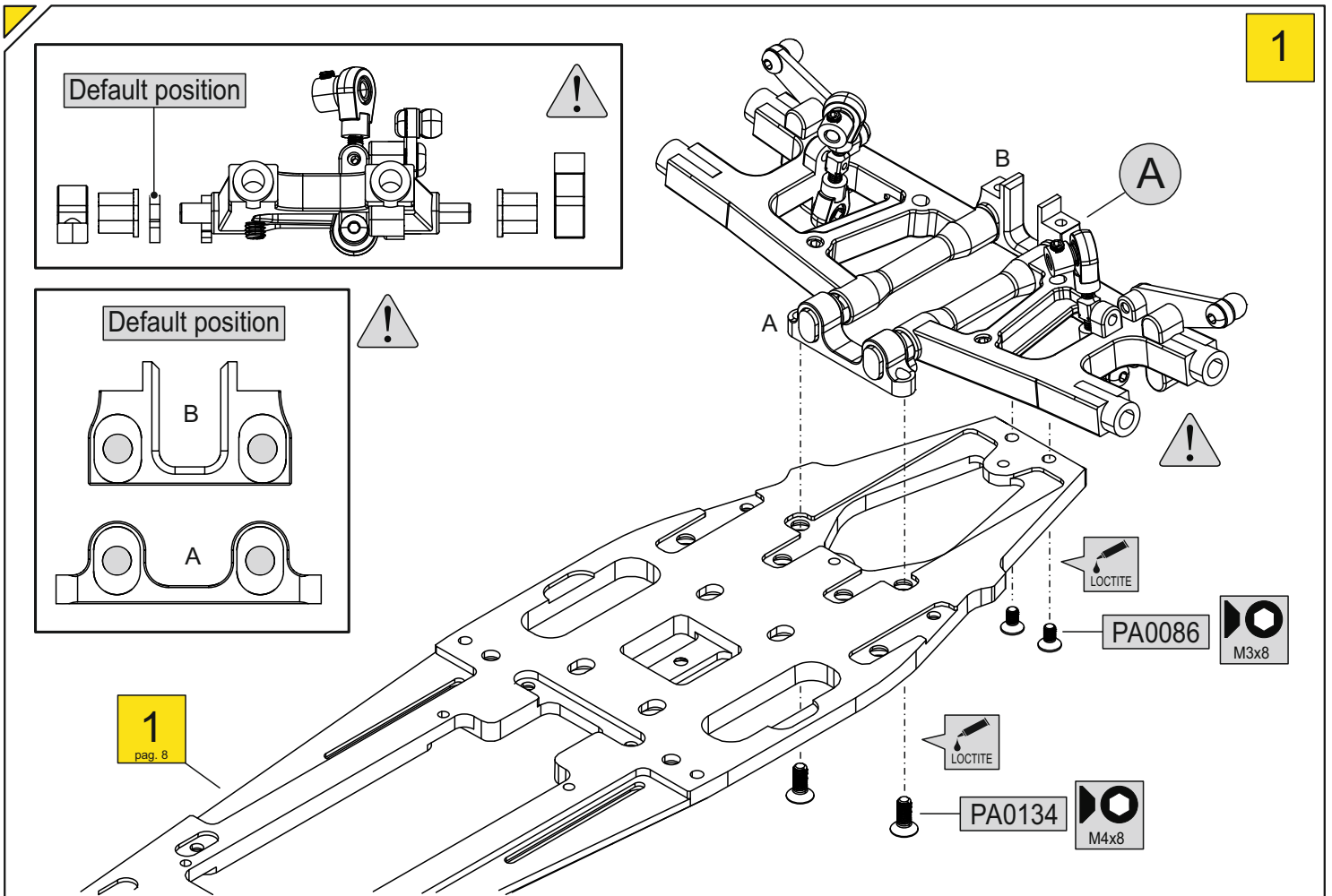
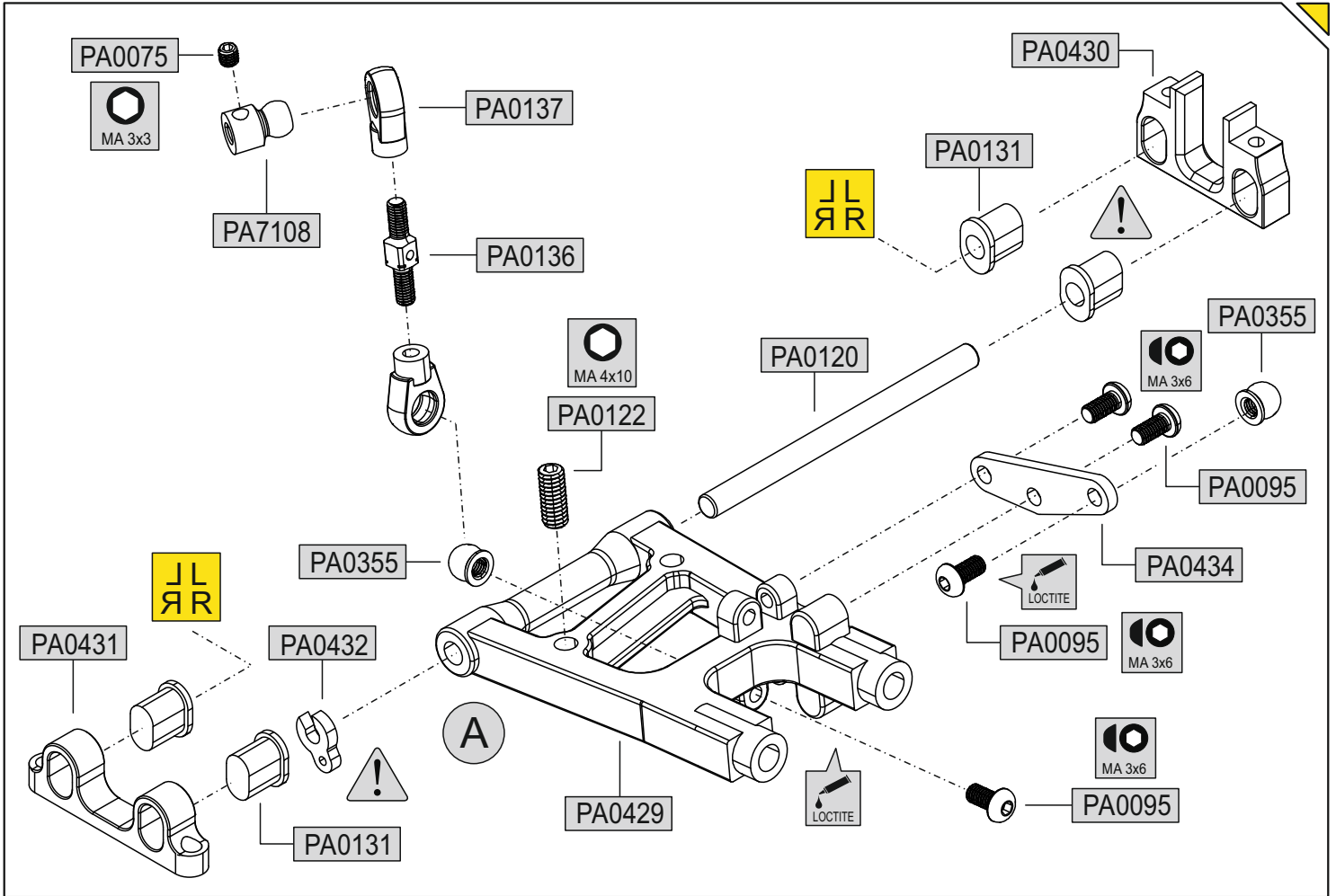

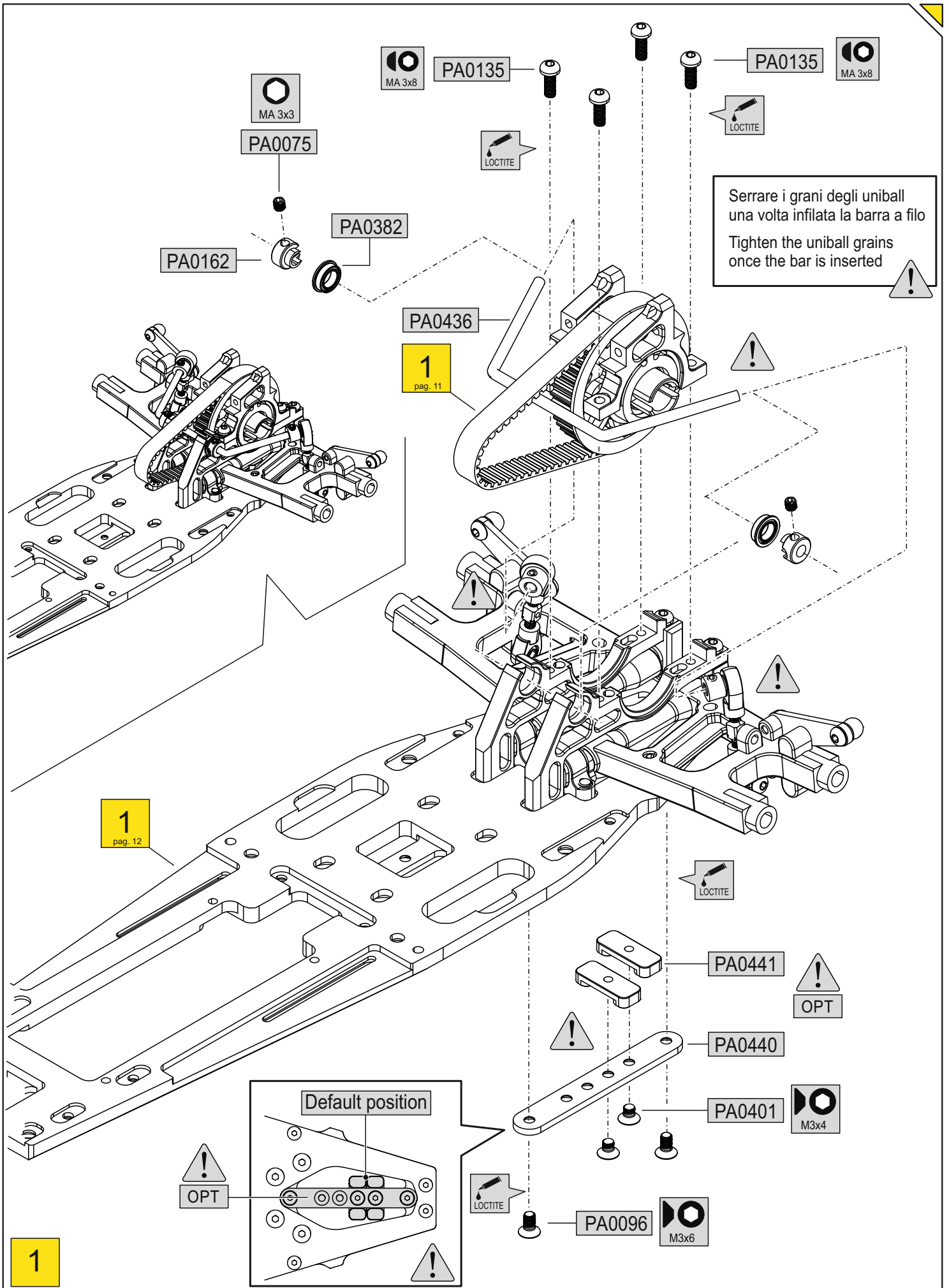

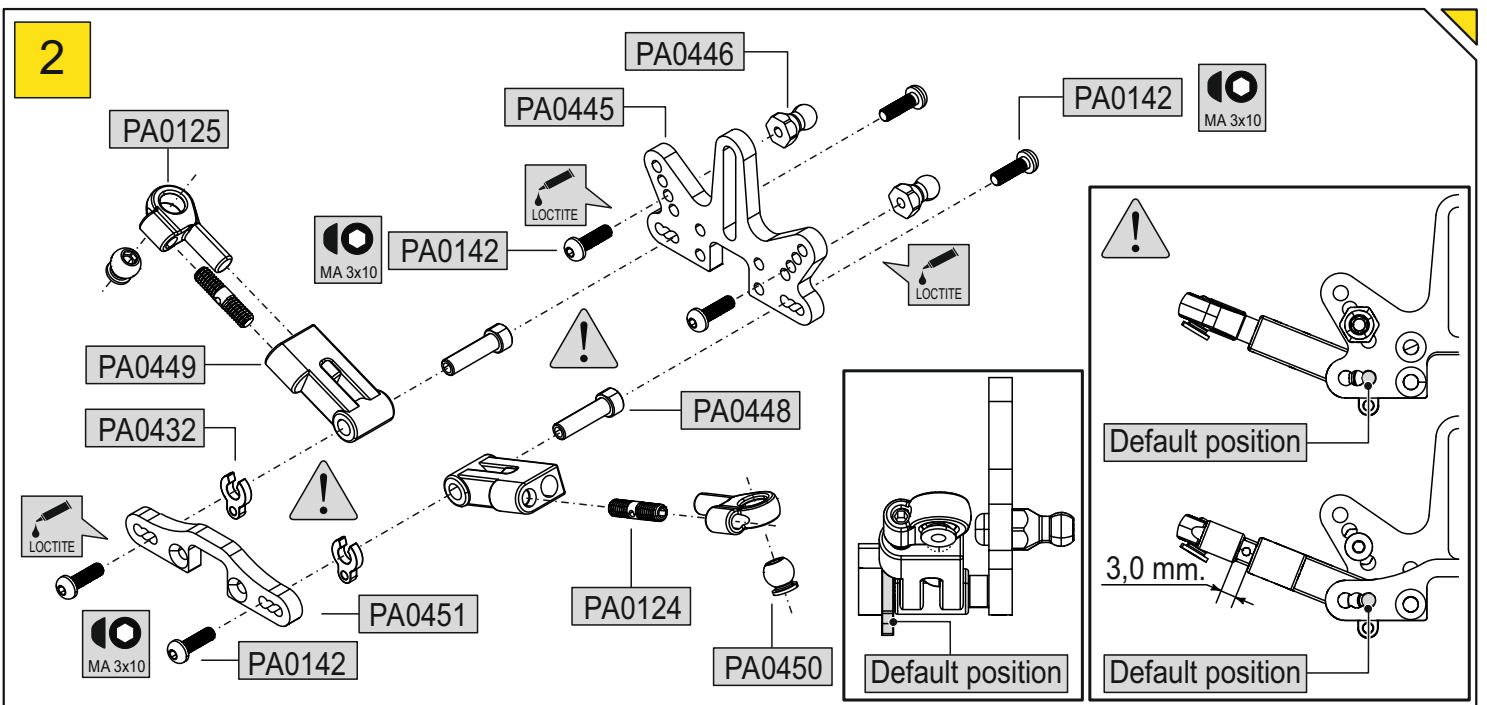
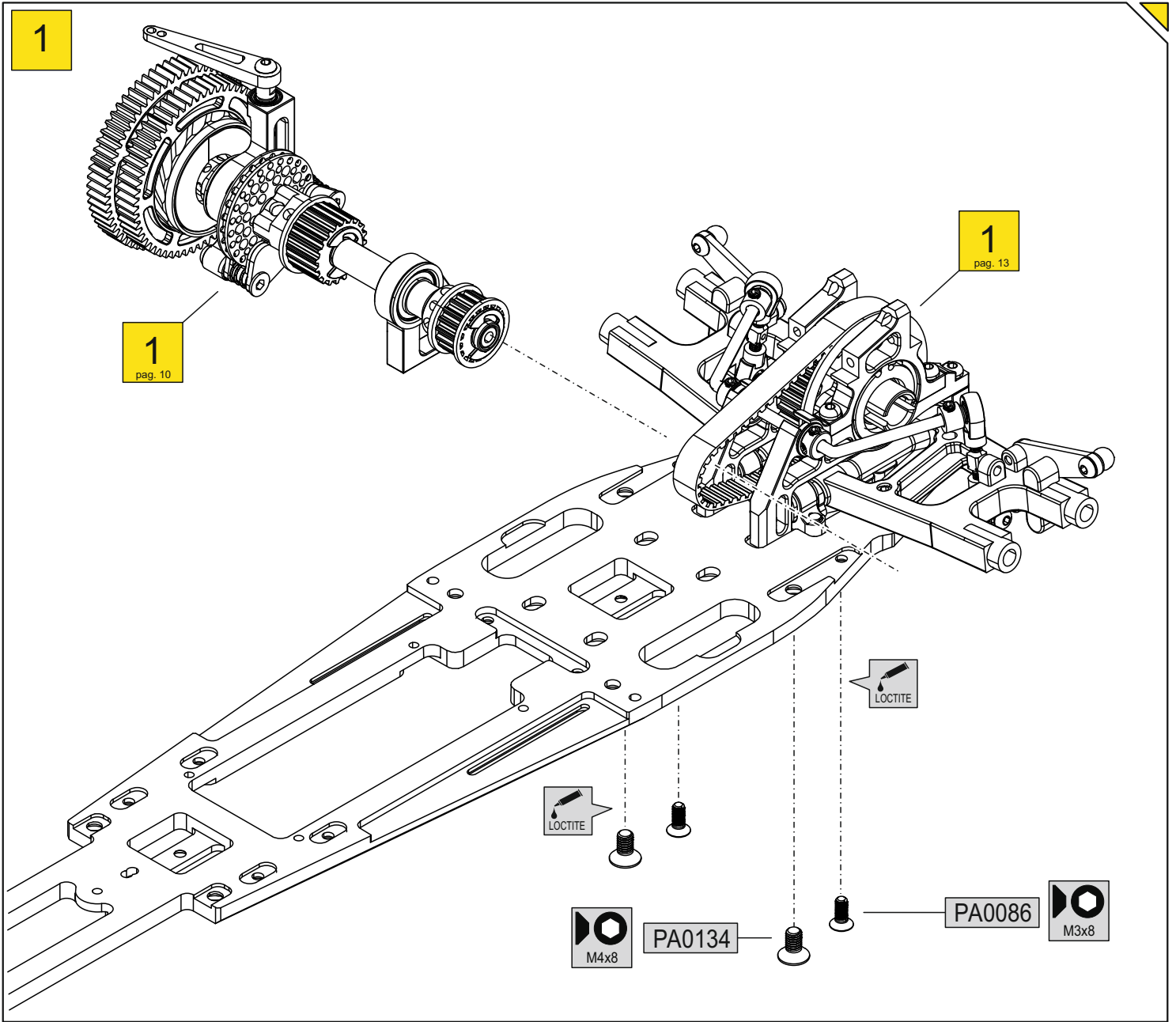

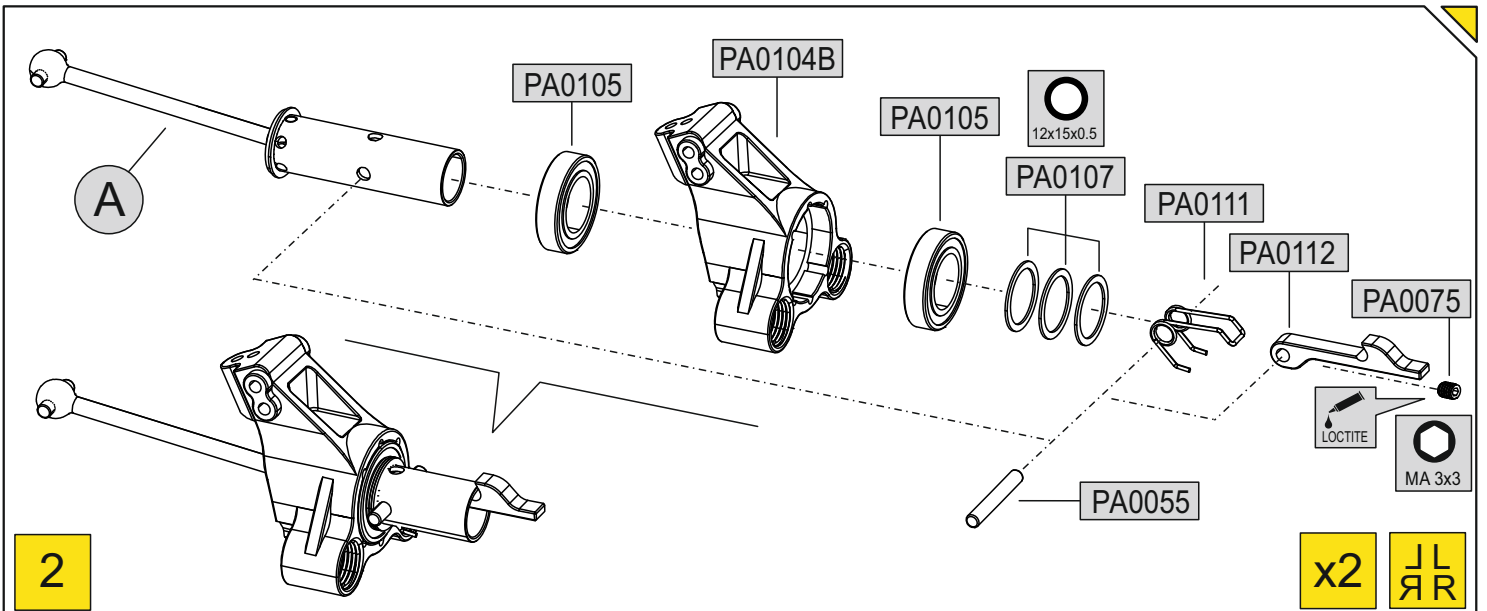
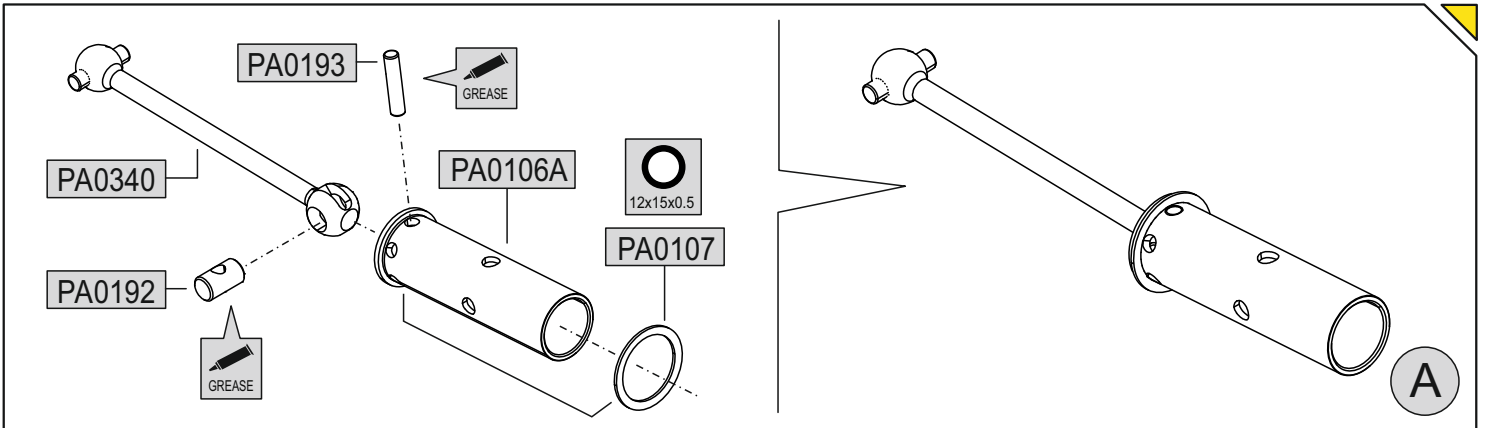
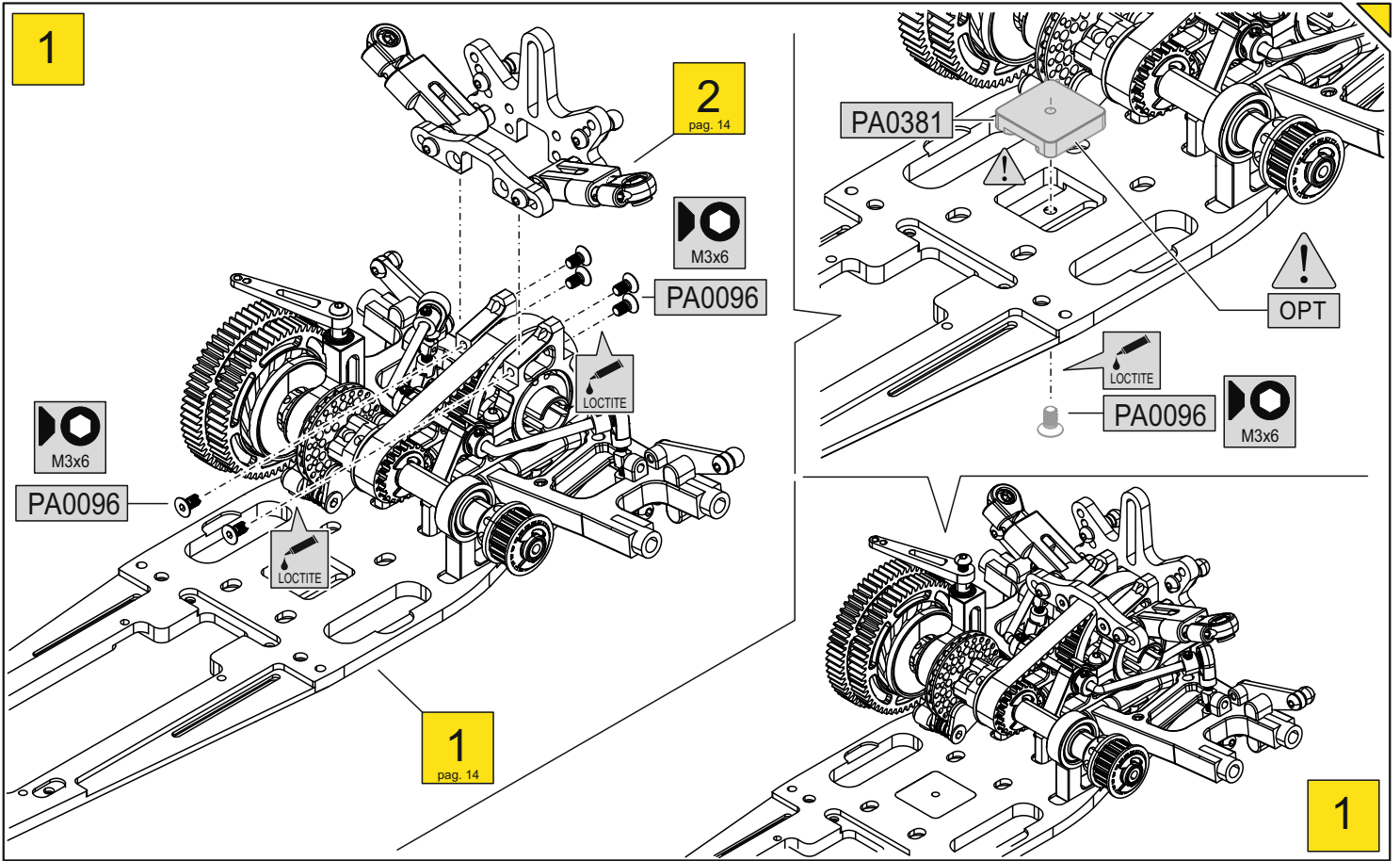

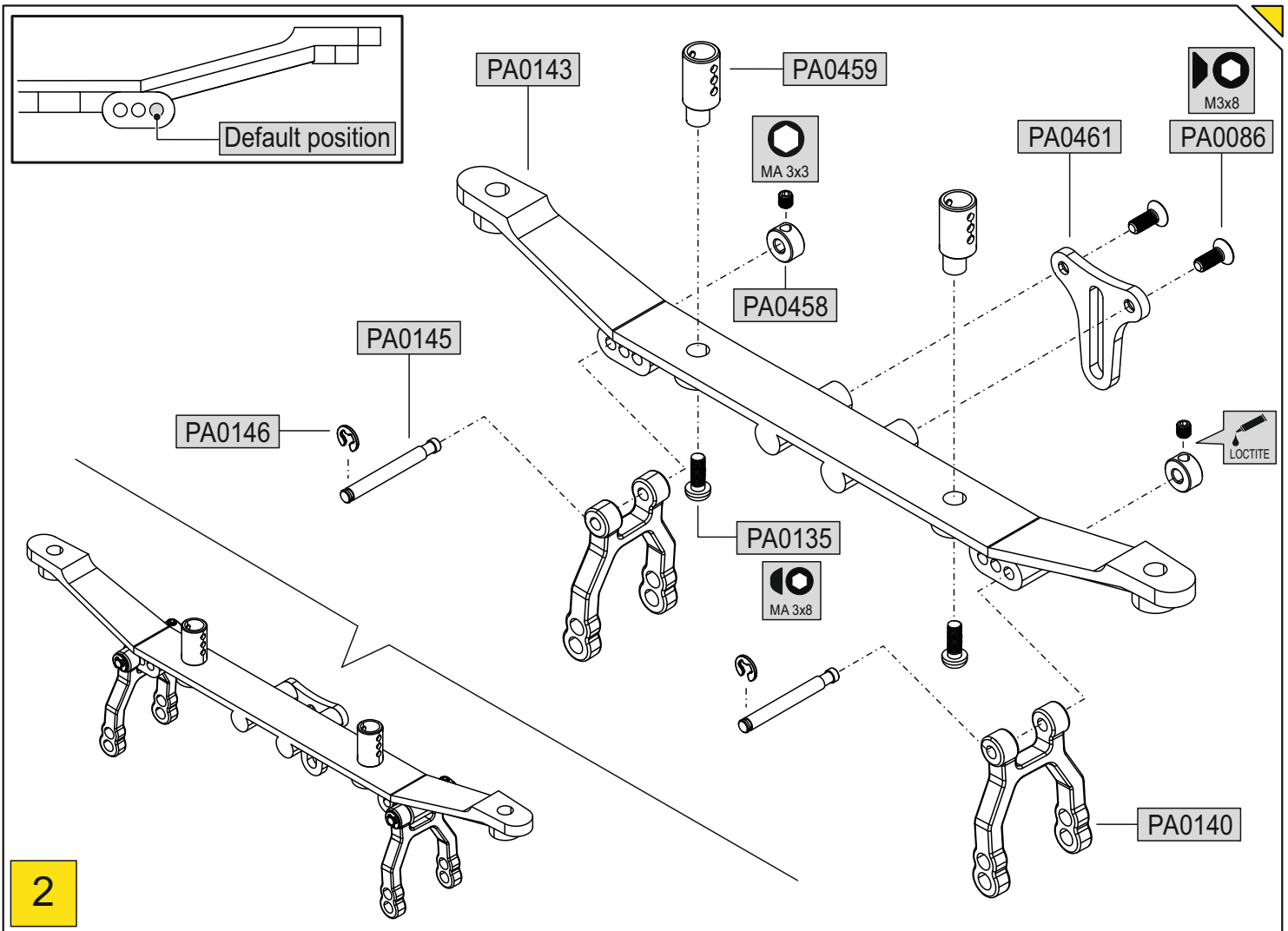
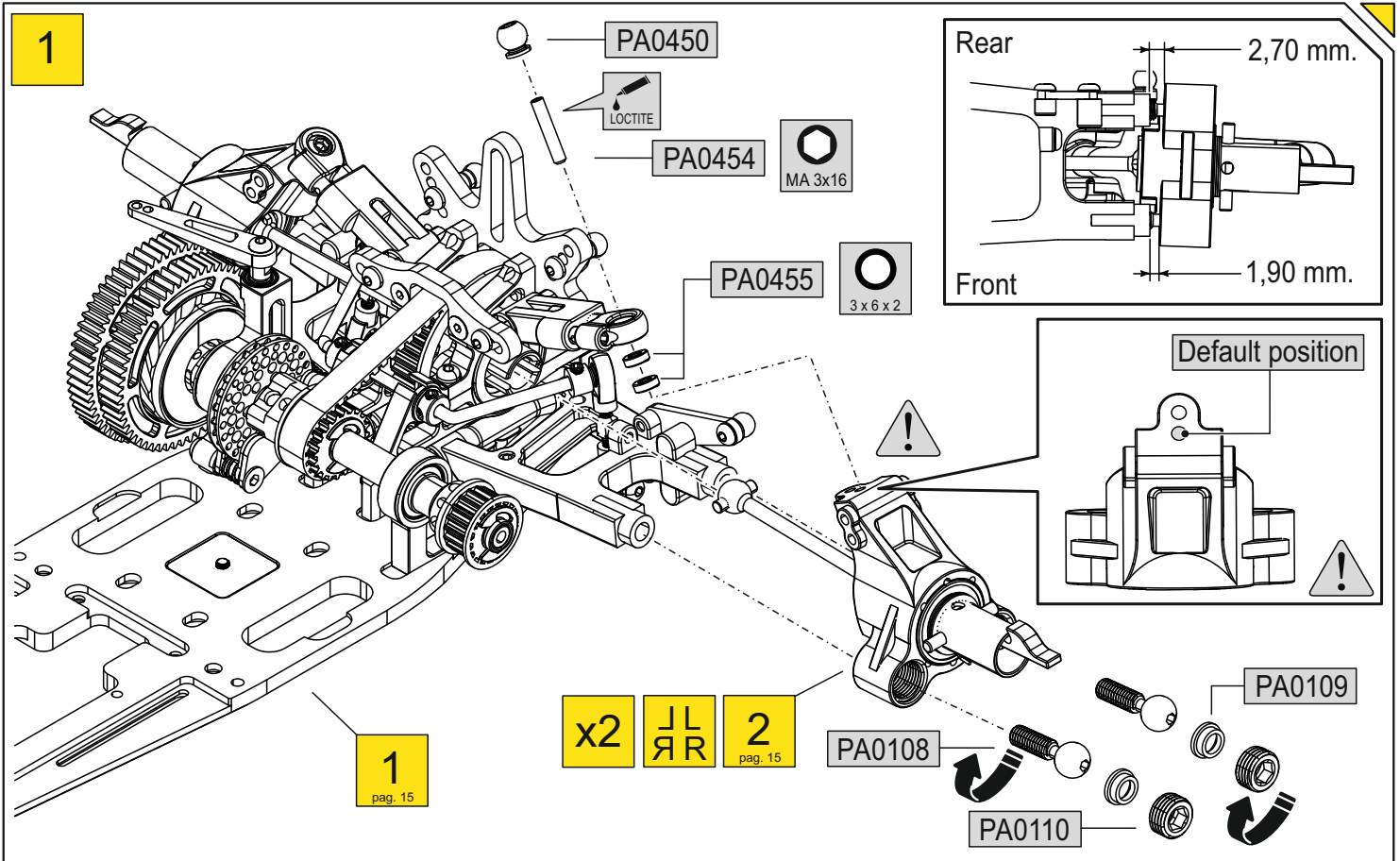

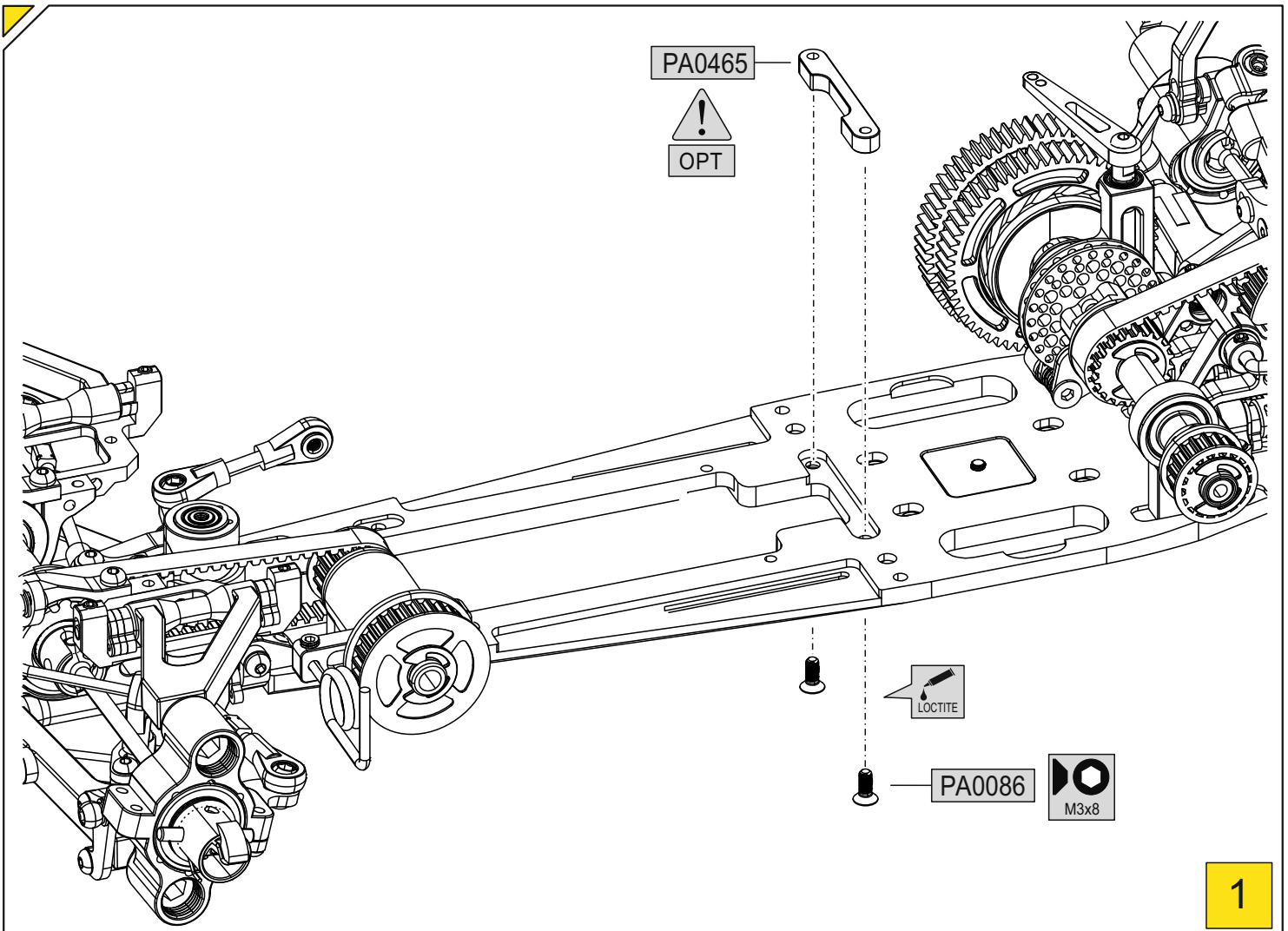
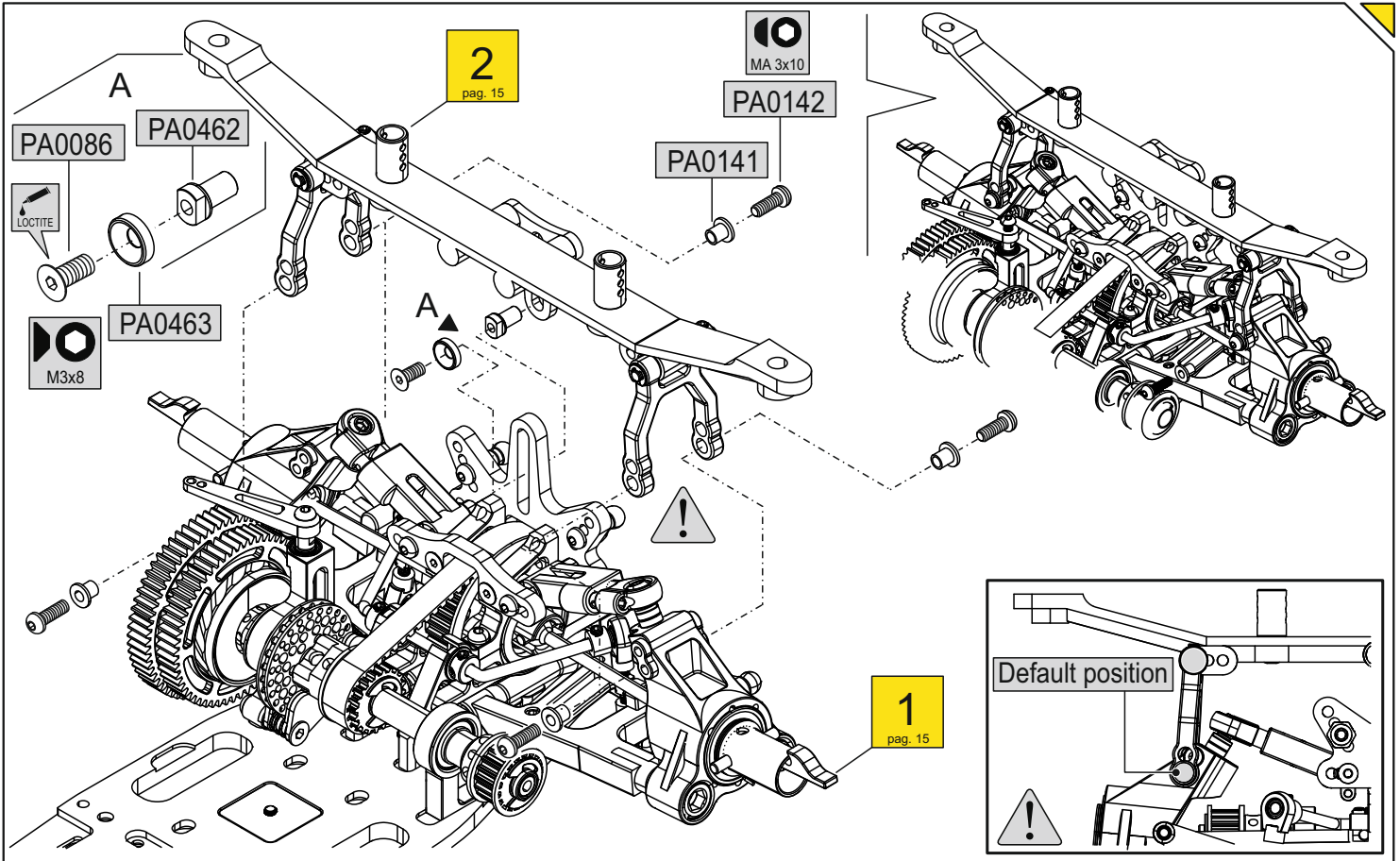

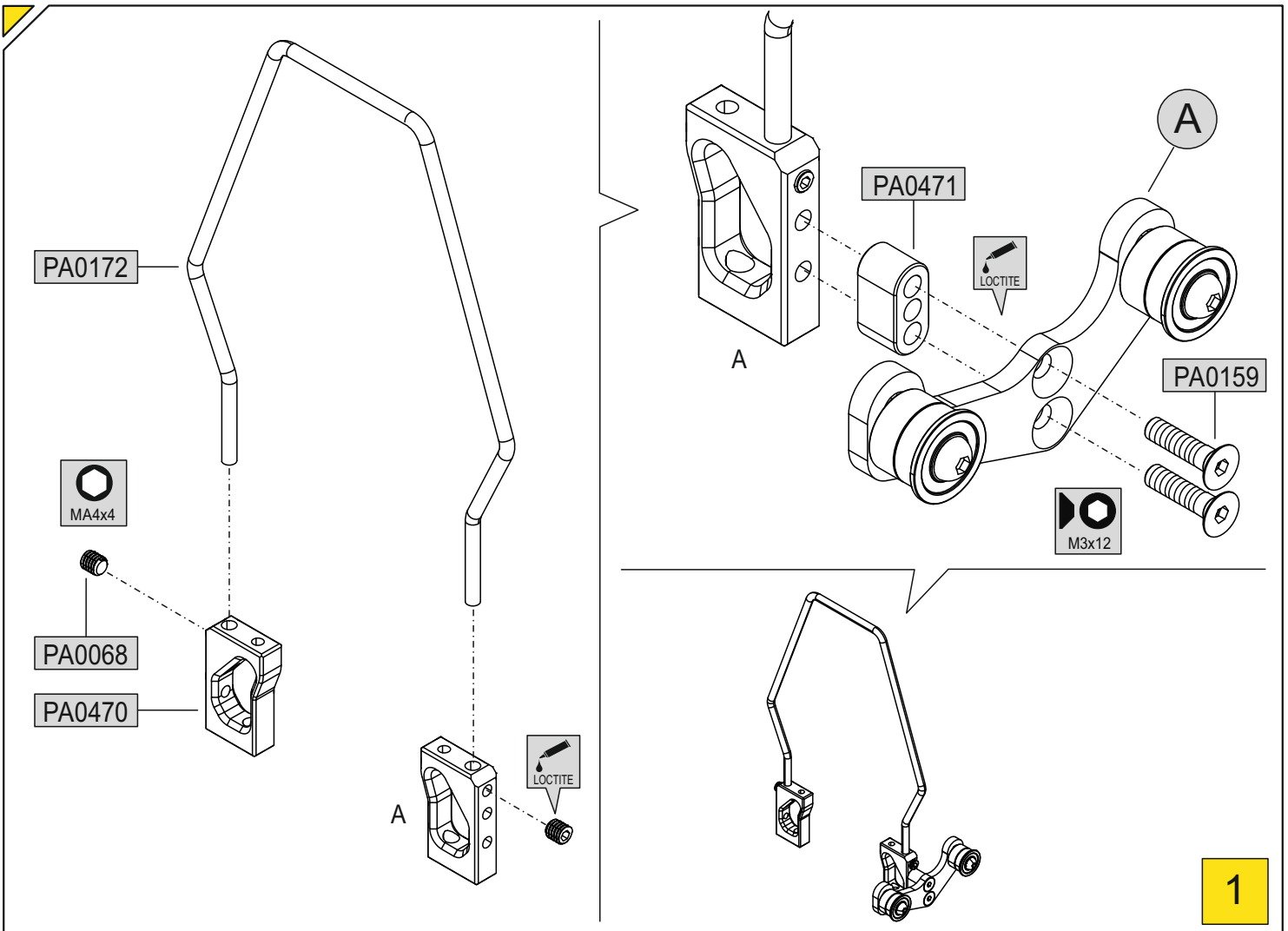
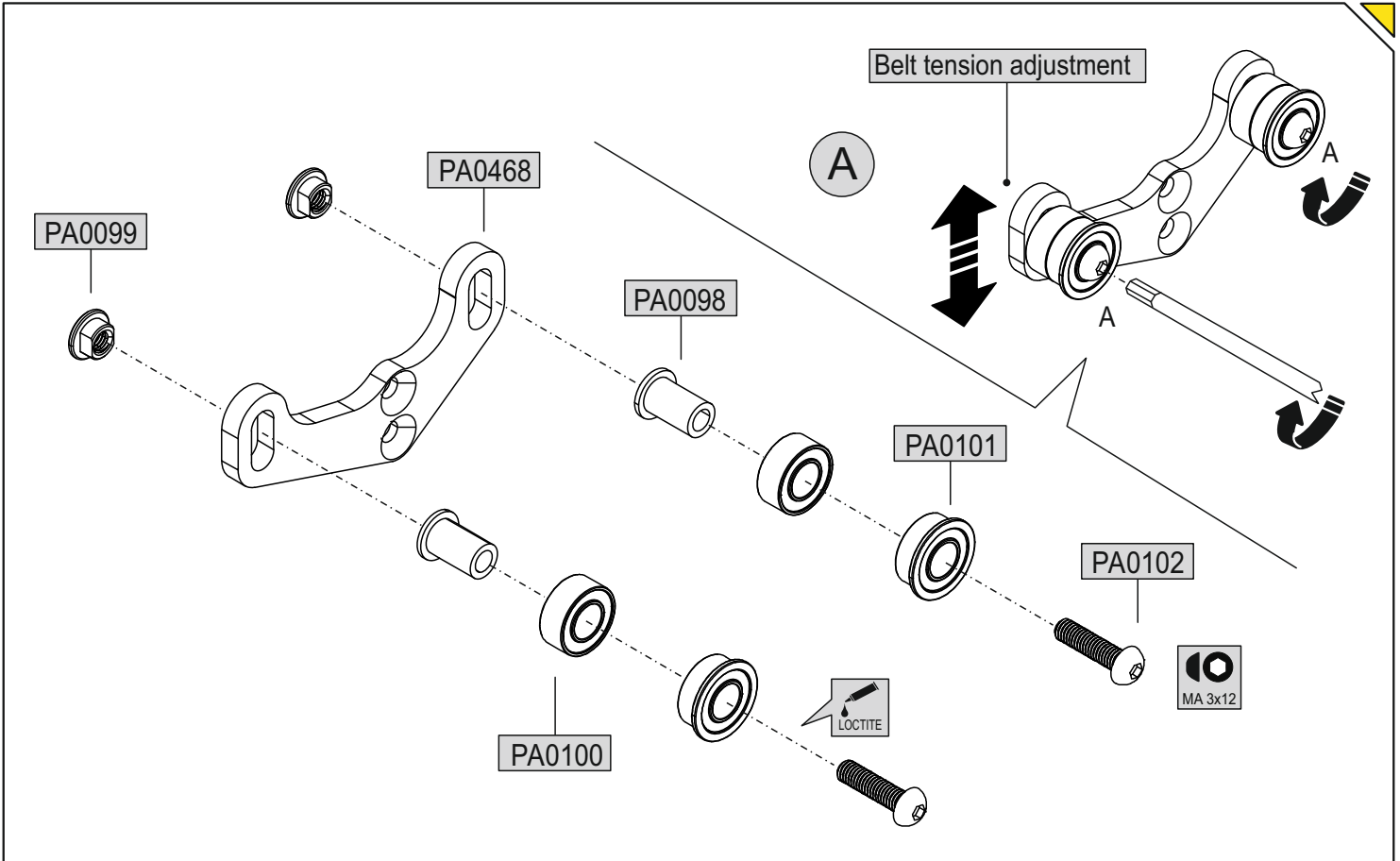

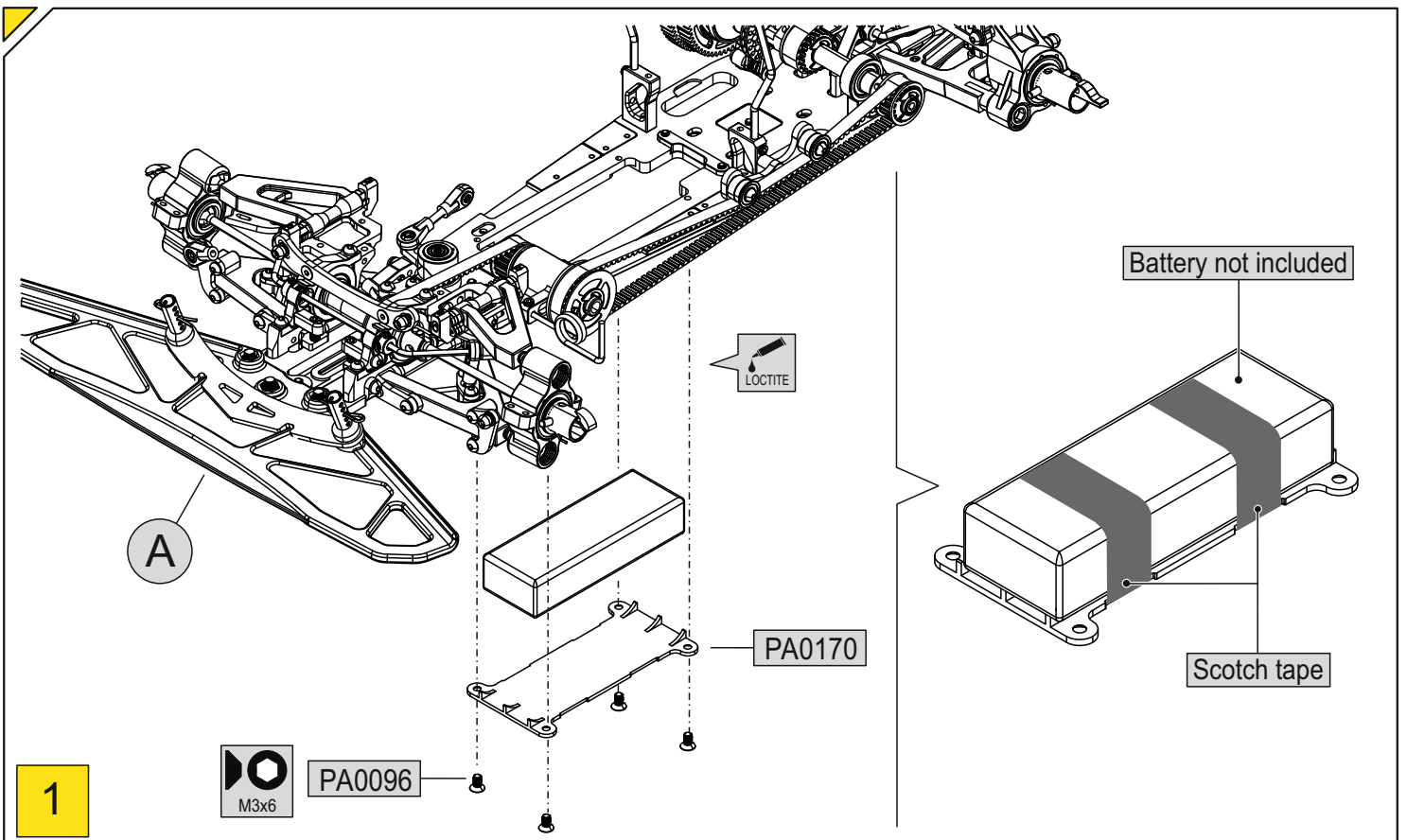
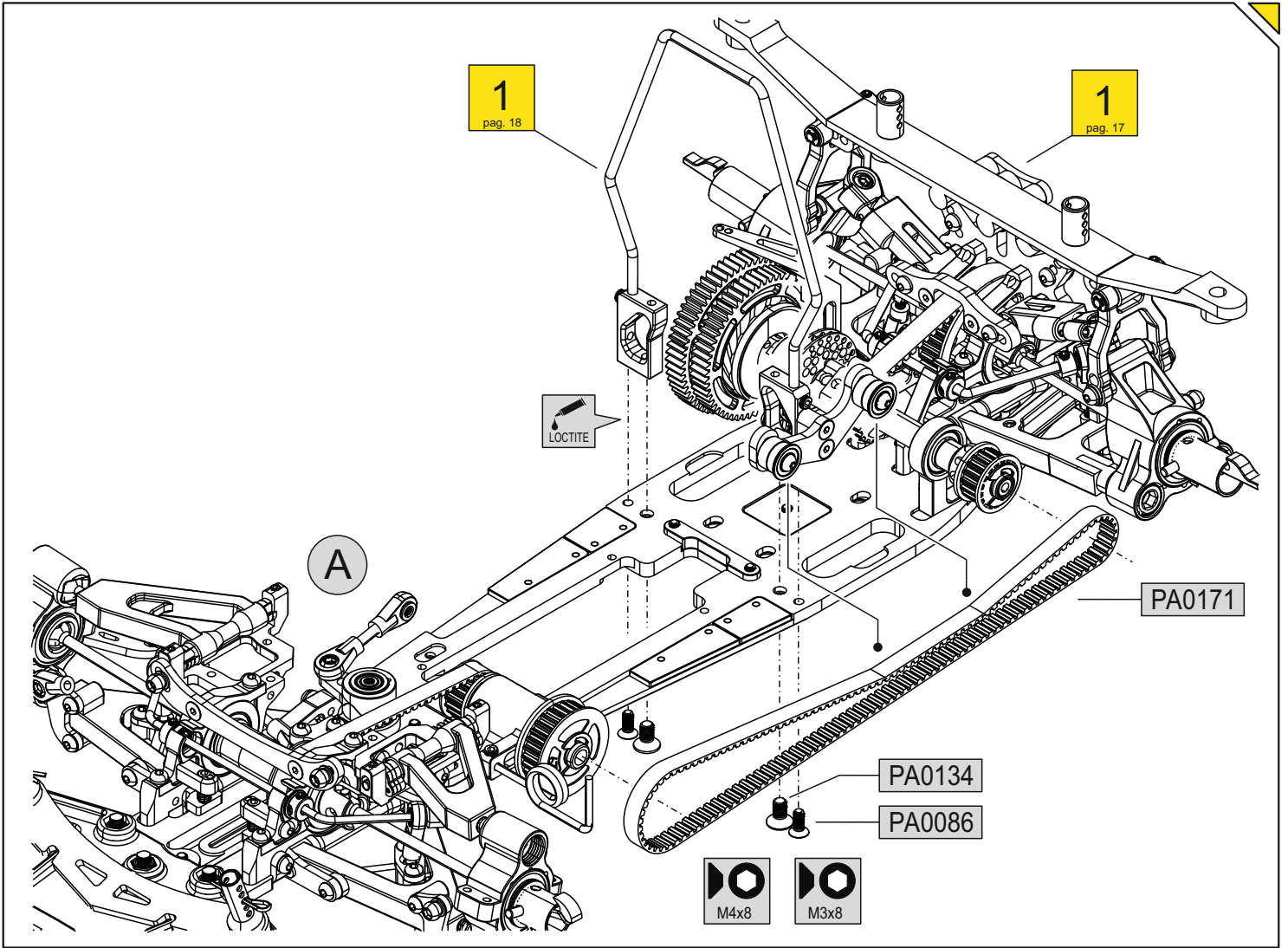

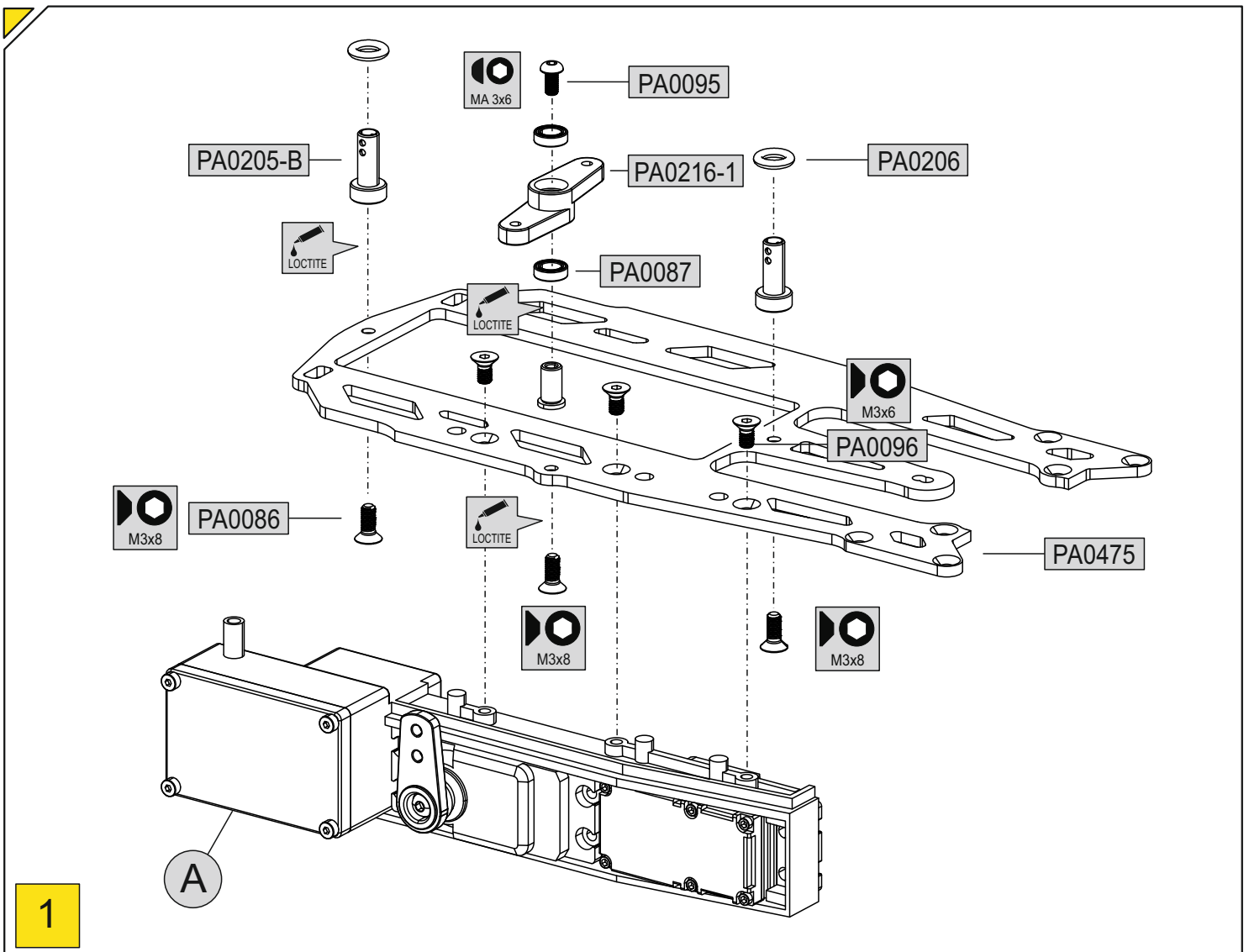
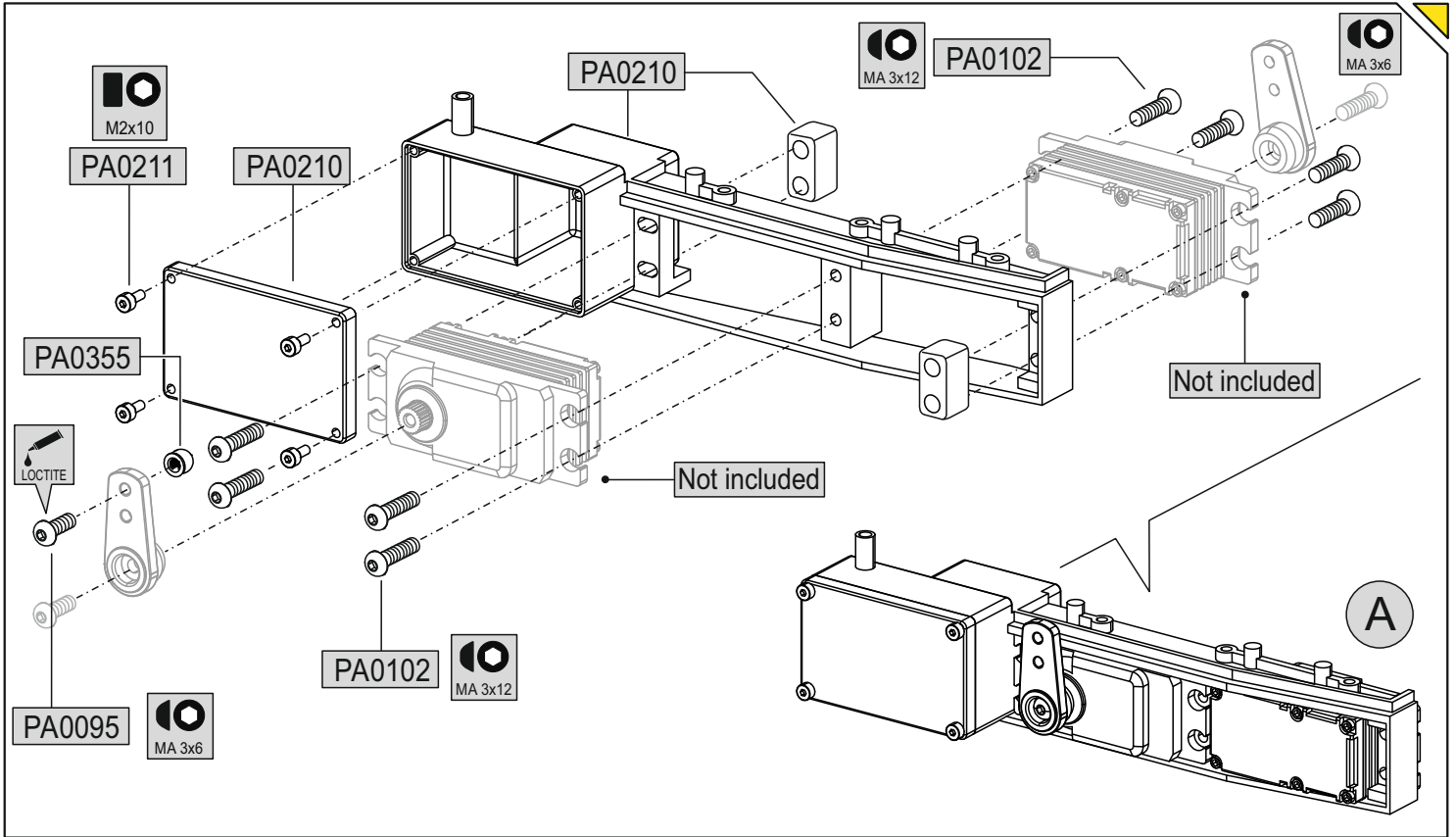

1

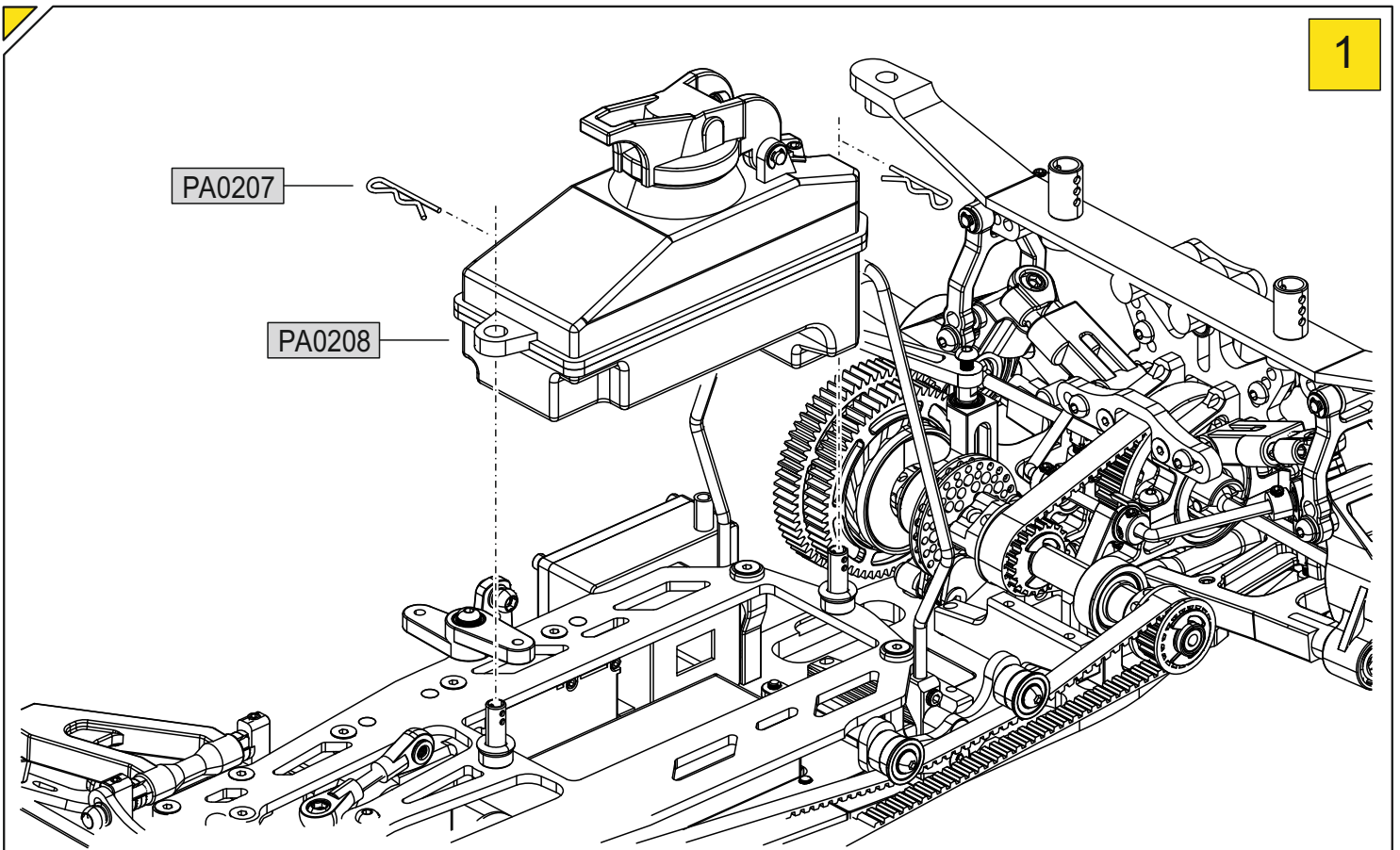
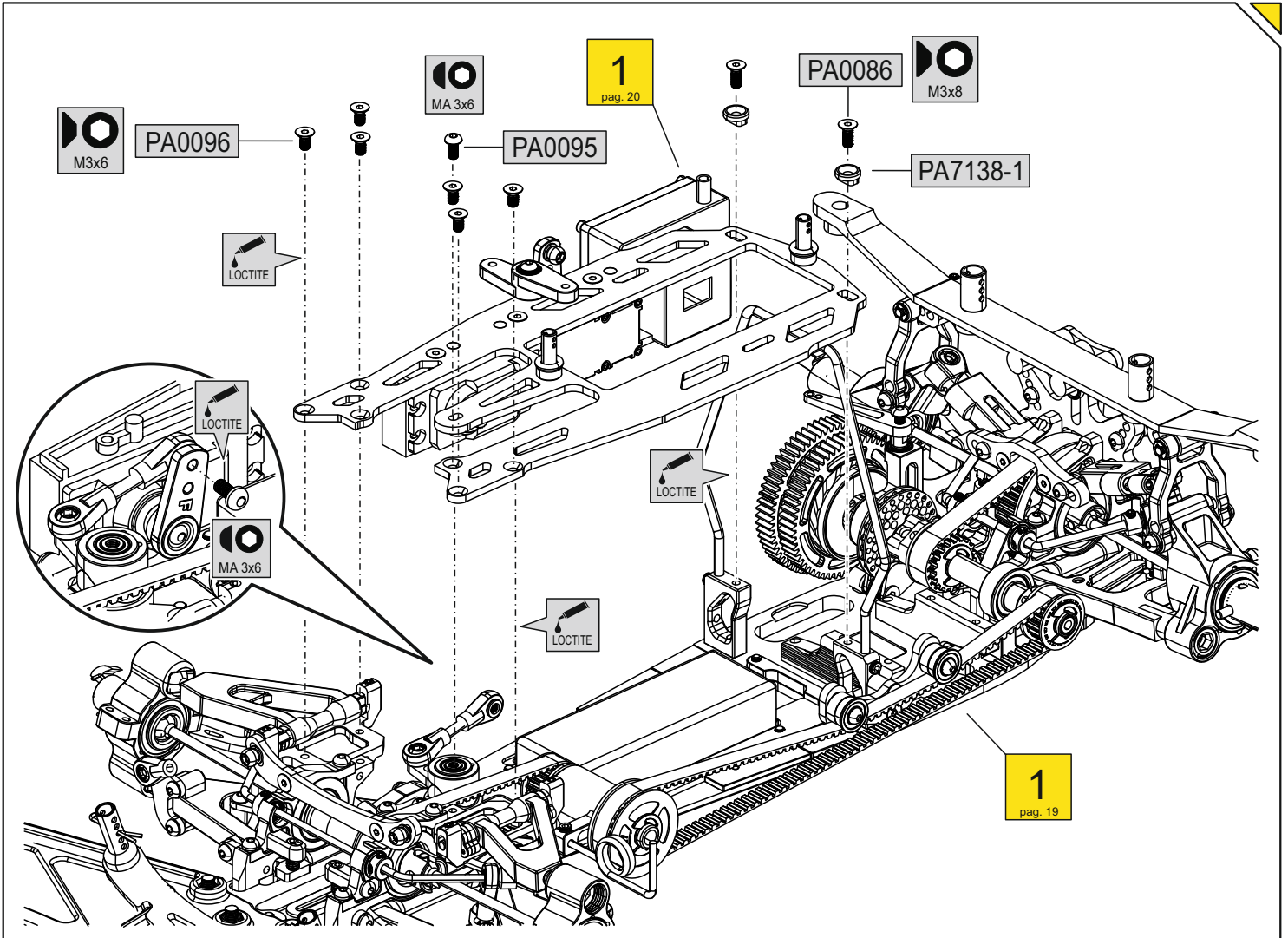

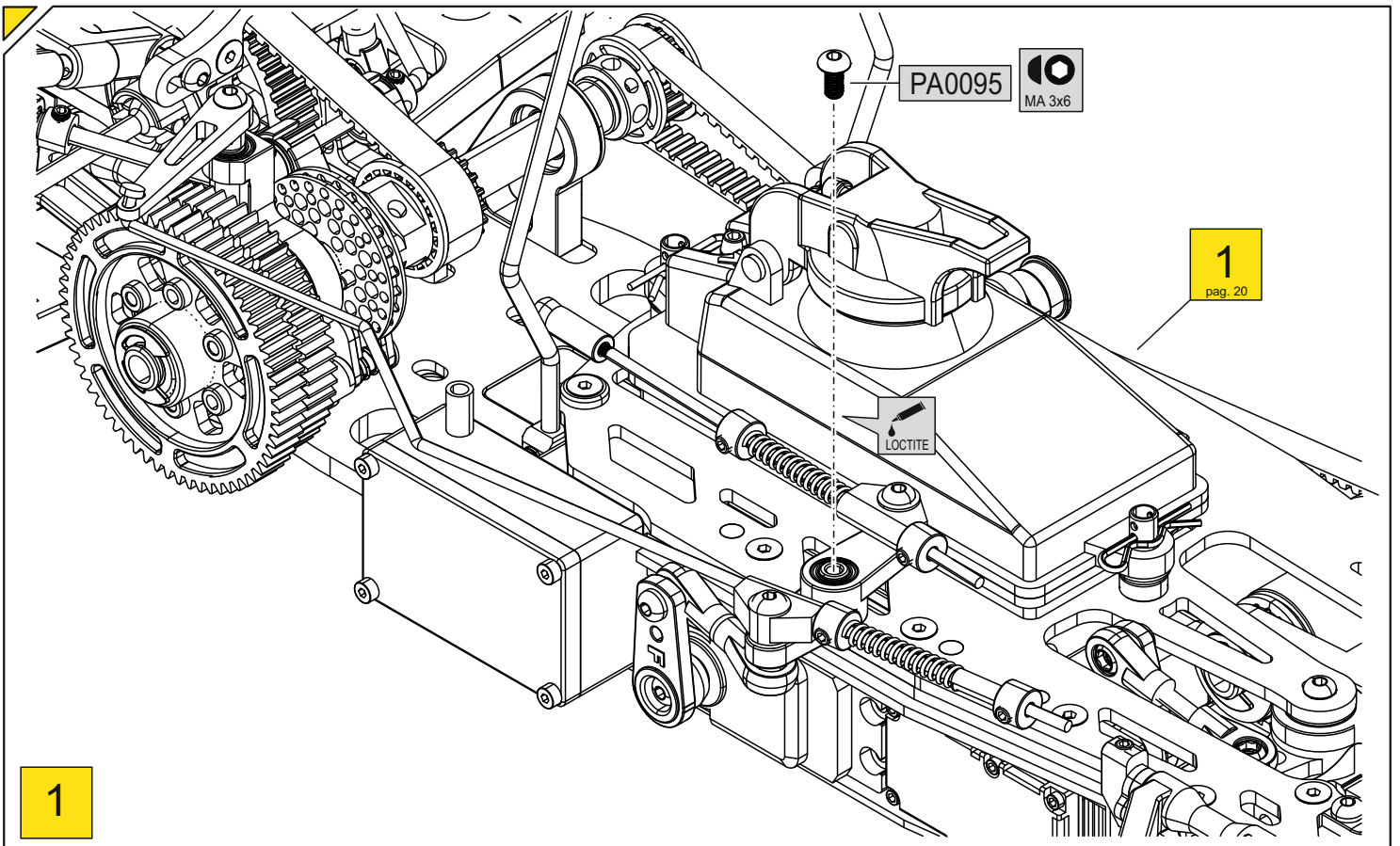
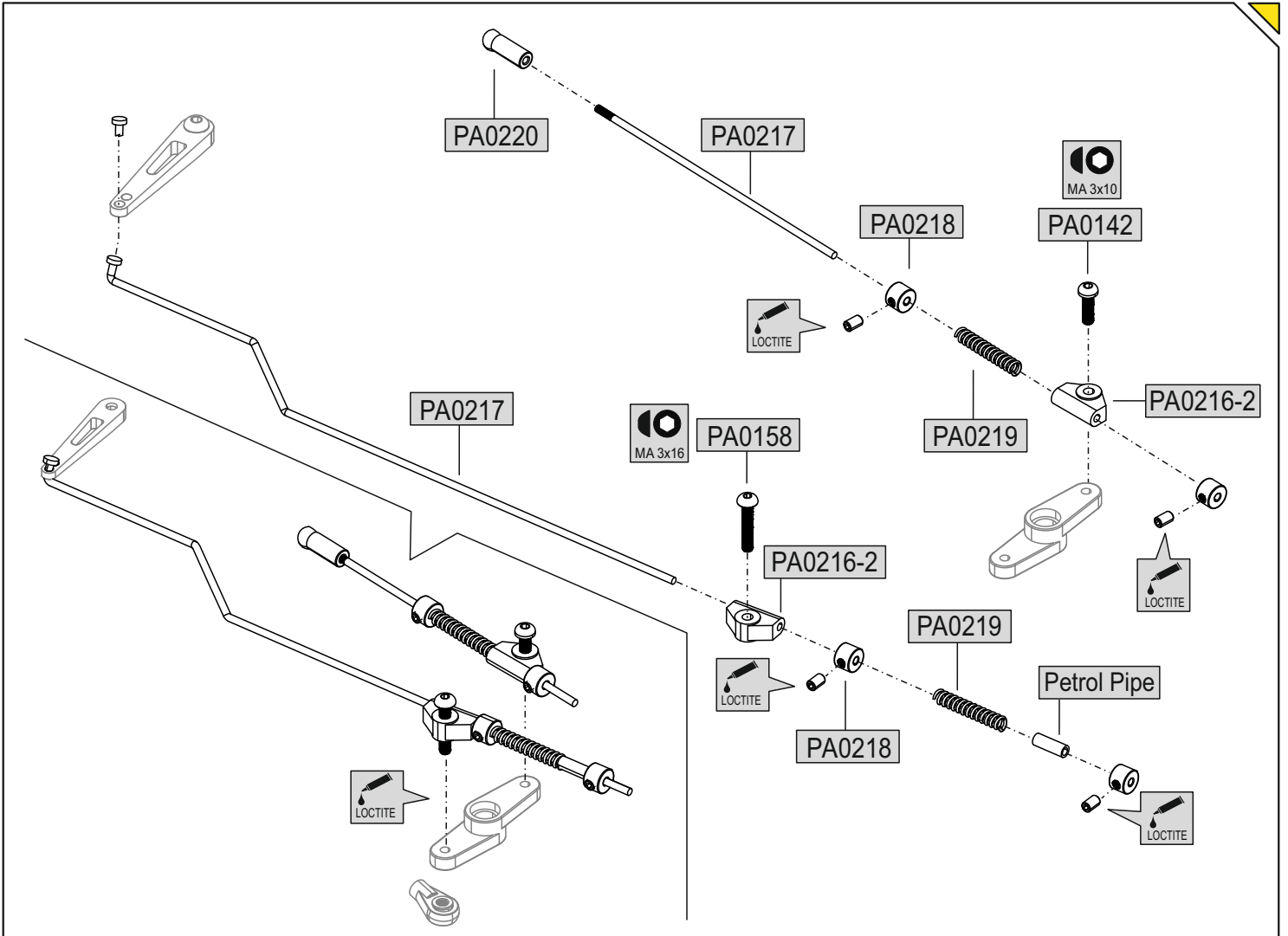

1

NOTA: a seconda dei tipi di motore, potrebbe essere necessario aggiungere rasamenti per chiudere il gioco assiale della campana.

NOTE: depending on the engine types, it could be necessary add shims to close the axial play of the bell.

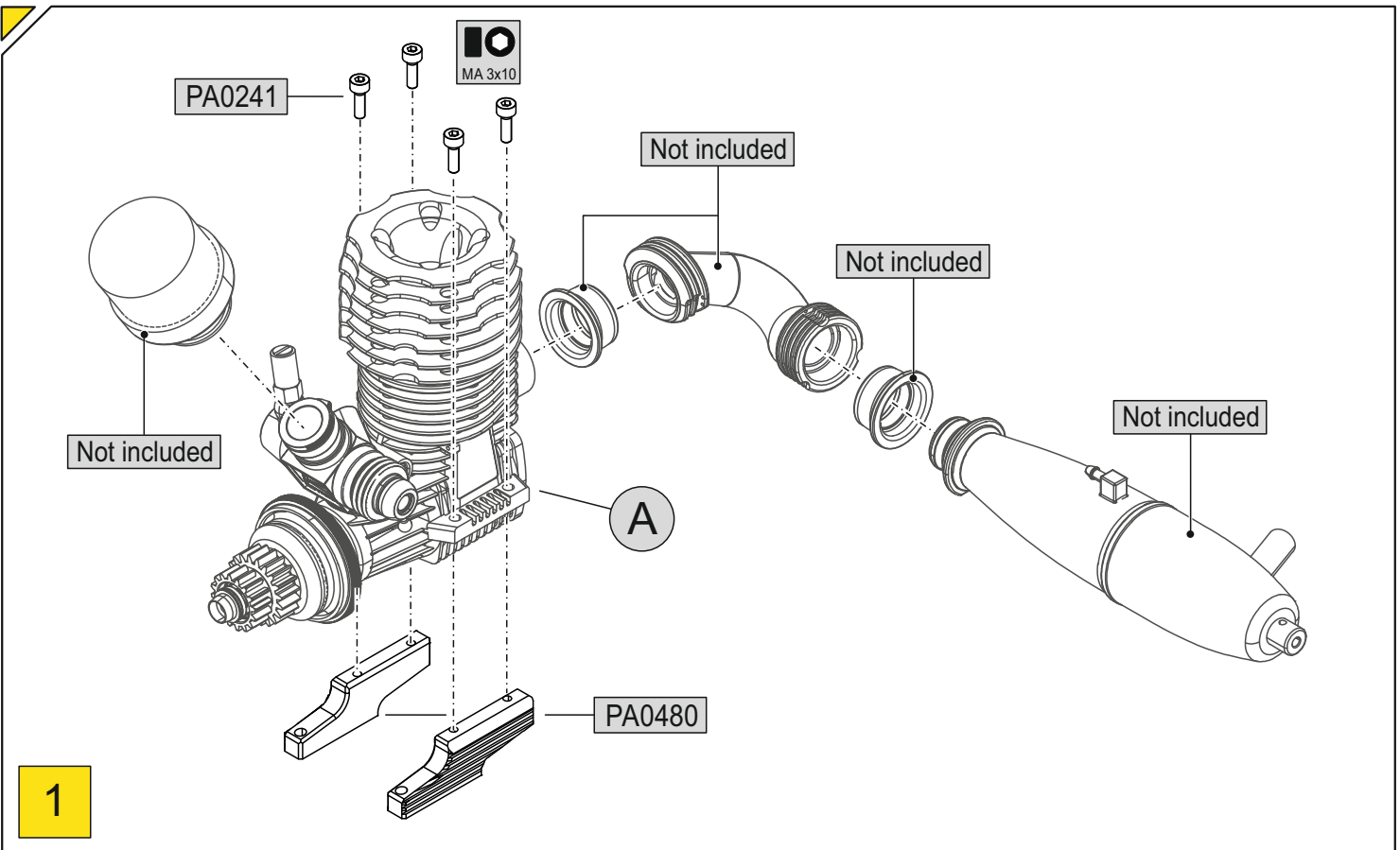
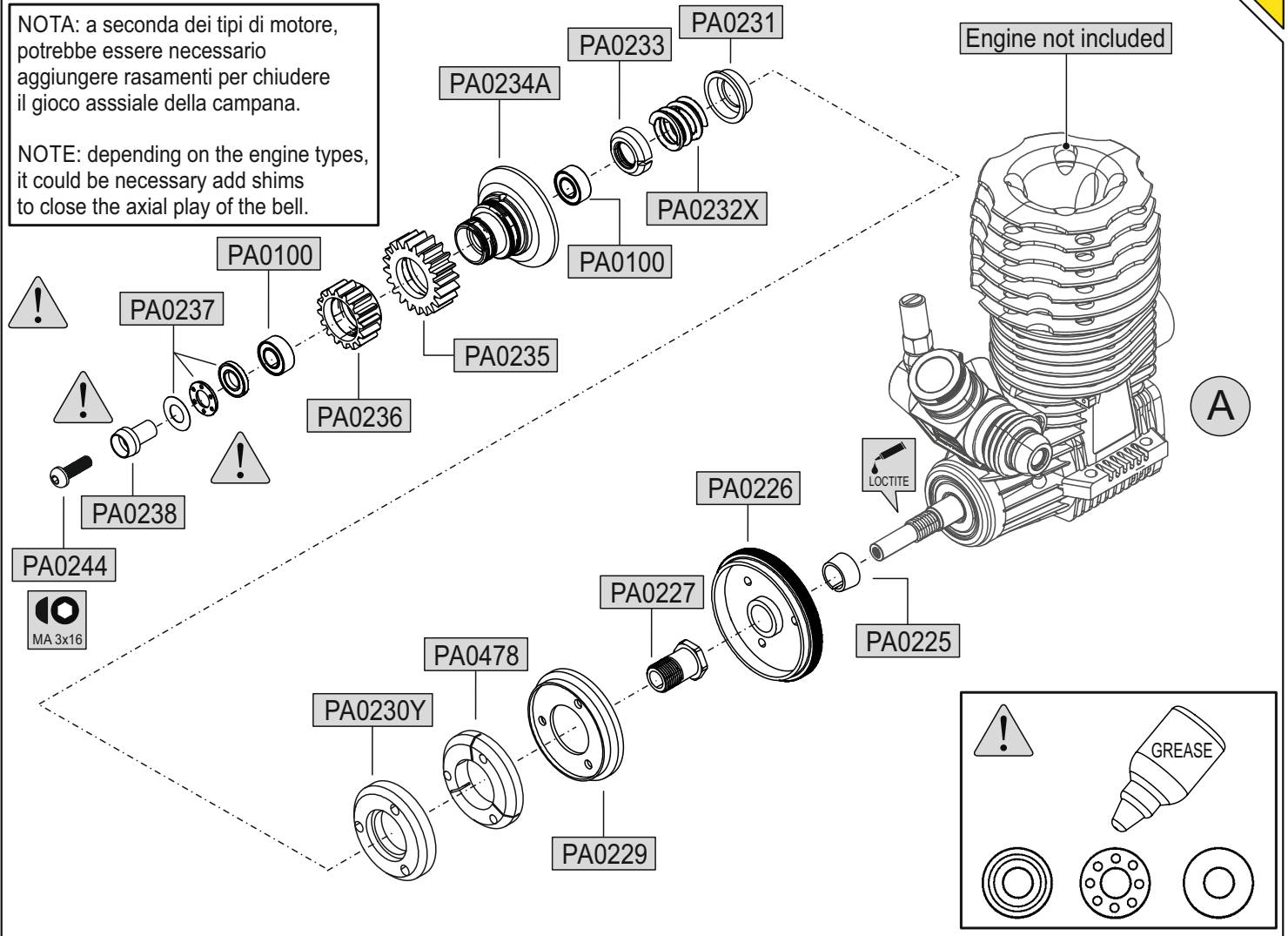

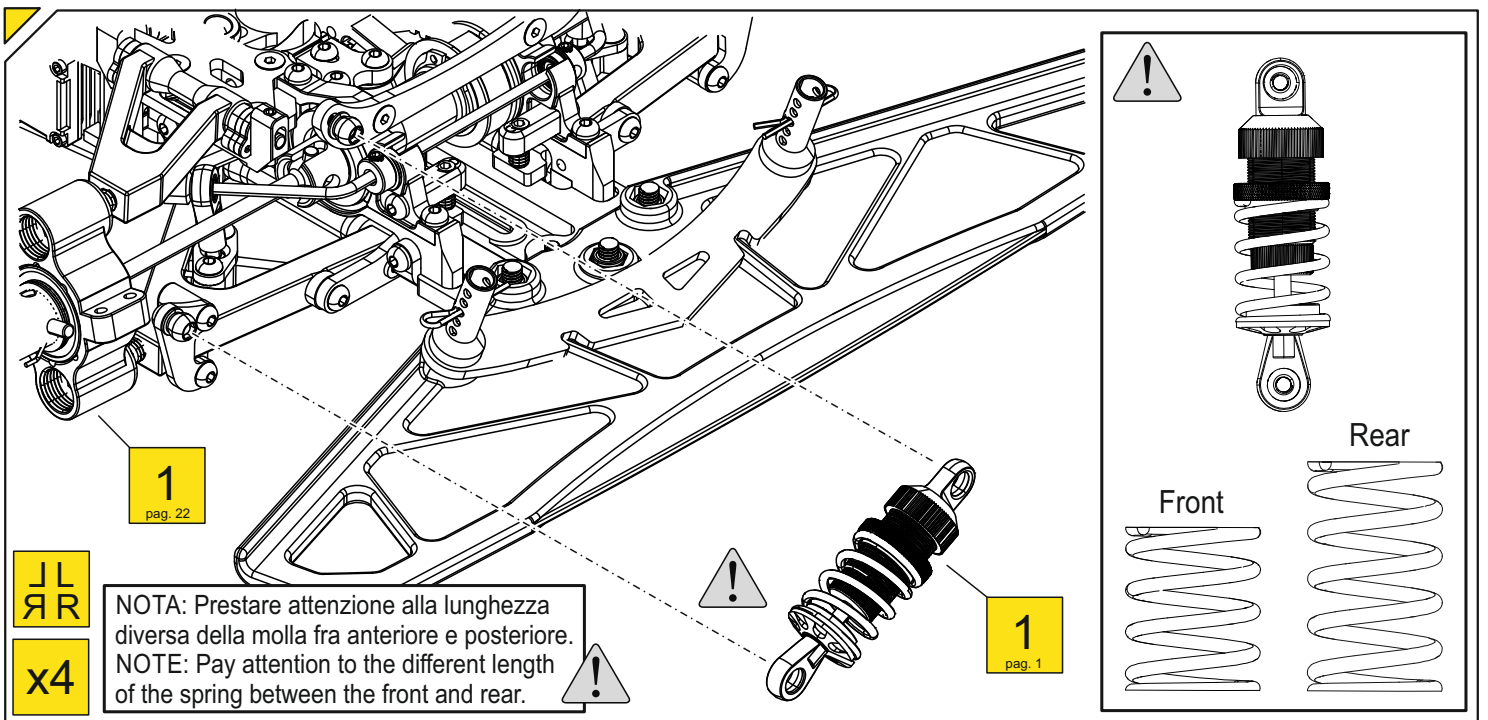
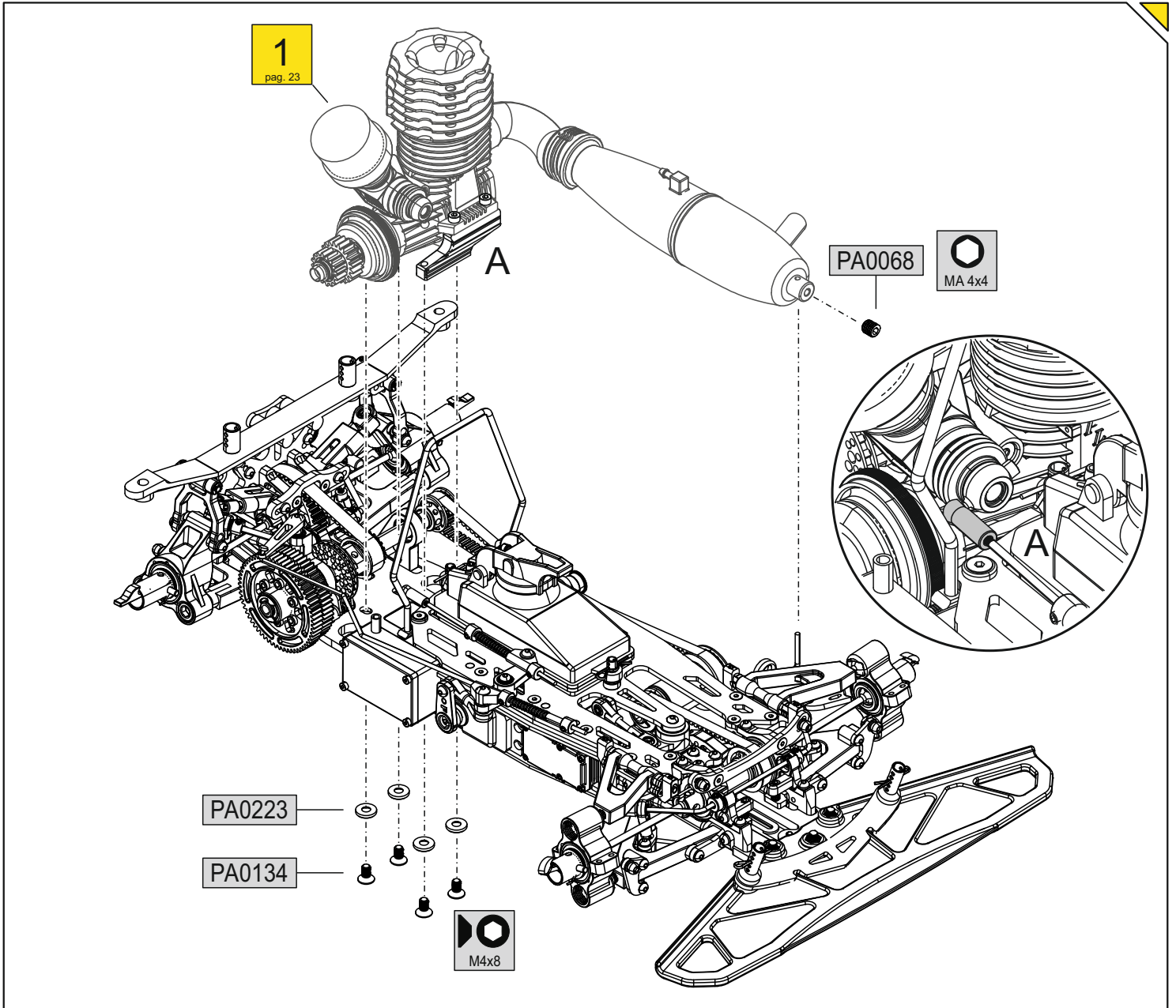

LR
RR
x4

NOTA: Prestare attenzione alla lunghezza diversa della molla fra anteriore e posteriore.
NOTE: Pay attention to the different length of the spring between the front and rear.

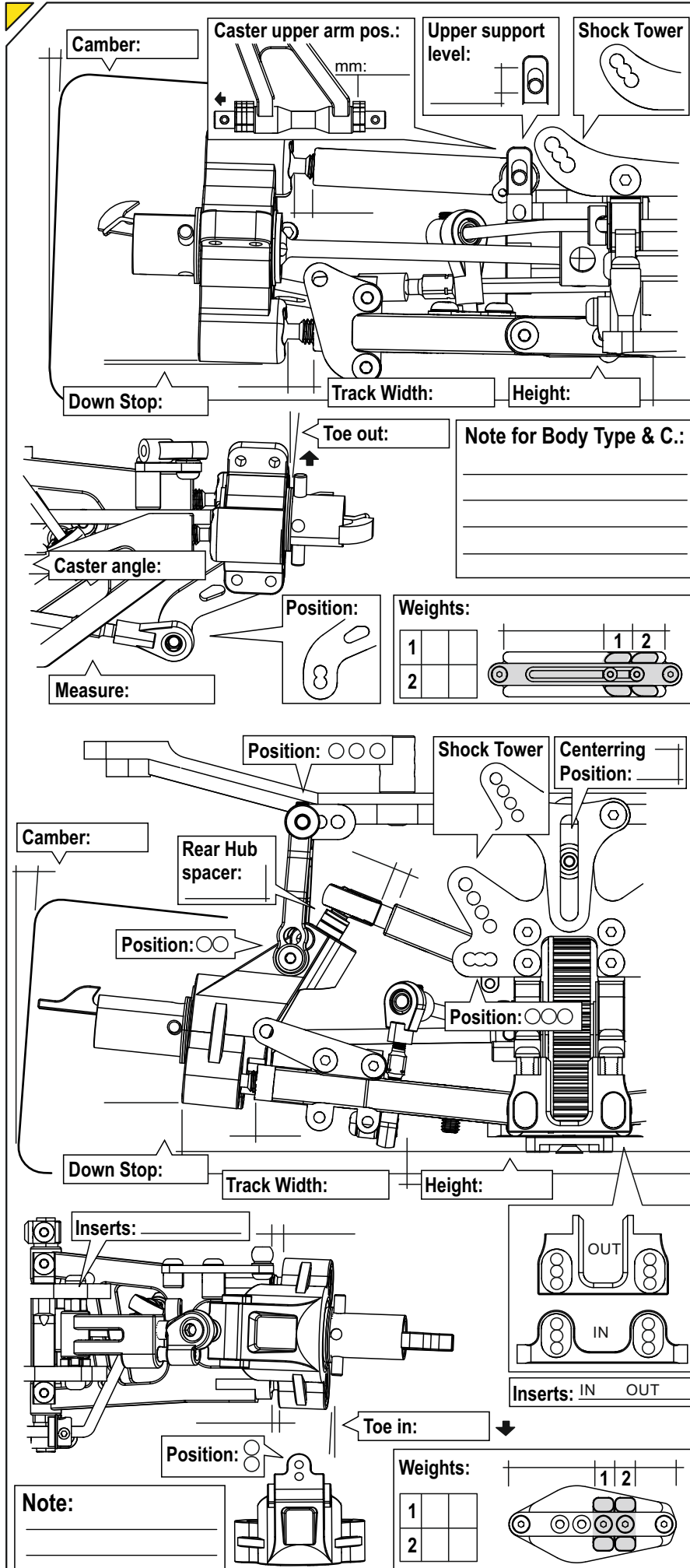

DRIVER	
DATE	
TRACK	

Traction:

LOW <input type="checkbox"/>	MEDIUM <input type="checkbox"/>	HIGH <input type="checkbox"/>
------------------------------	---------------------------------	-------------------------------

Layout:

SLOW <input type="checkbox"/>	MIXED <input type="checkbox"/>	FAST <input type="checkbox"/>
-------------------------------	--------------------------------	-------------------------------

Engine:

TYPE	
GLOW-PLUG/FUEL	
PIPE/MANIFOLD	

Clutch settings:

SHOE/BELL	
CLEARANCE(mm)	
AXIALPLAY(mm)	
SPRING	
TENSION(mm)	

Tyres:

FRONT		BRAND	REAR	
LEFT	RIGHT		LEFT	RIGHT
		SHORE		
		DIAMETER START		
		DIAMETER STOP		

Shock Absorbers:

FRONT		REAR	
PISTON		PISTON	
OIL		OIL	
SPRING		SPRING	

FRONT - Anti roll bar:

2,1 <input type="checkbox"/>	2,3 <input type="checkbox"/>	2,5 <input type="checkbox"/>	opt: <input type="checkbox"/>
------------------------------	------------------------------	------------------------------	-------------------------------

REAR - Anti roll bar:

2,6 <input type="checkbox"/>	2,8 <input type="checkbox"/>	3,0 <input type="checkbox"/>	opt: <input type="checkbox"/>
------------------------------	------------------------------	------------------------------	-------------------------------

Servo saver position:

mm. <input type="text"/>		<input type="checkbox"/> FRONT	<input type="checkbox"/> REAR
--------------------------	--	--------------------------------	-------------------------------

Pinion 1 st

18T <input type="checkbox"/>	19T <input type="checkbox"/>	20T <input type="checkbox"/>
------------------------------	------------------------------	------------------------------

Pinion 2 st

23T <input type="checkbox"/>	24T <input type="checkbox"/>	25T <input type="checkbox"/>
------------------------------	------------------------------	------------------------------

Spur 1 st

59T <input type="checkbox"/>	60T <input type="checkbox"/>	61T <input type="checkbox"/>
------------------------------	------------------------------	------------------------------

Spur 2 st

55T <input type="checkbox"/>	56T <input type="checkbox"/>	57T <input type="checkbox"/>
------------------------------	------------------------------	------------------------------